

---

Stream: Independent Submission  
RFC: [9361](#)  
Category: Informational  
Published: March 2023  
ISSN: 2070-1721  
Author: G. Lozano  
*ICANN*

# RFC 9361

## ICANN Trademark Clearinghouse (TMCH) Functional Specifications

---

### Abstract

This document describes the requirements, the architecture, and the interfaces between the ICANN Trademark Clearinghouse (TMCH) and Domain Name Registries, as well as between the ICANN TMCH and Domain Name Registrars for the provisioning and management of domain names during Sunrise and Trademark Claims Periods.

### Status of This Memo

This document is not an Internet Standards Track specification; it is published for informational purposes.

This is a contribution to the RFC Series, independently of any other RFC stream. The RFC Editor has chosen to publish this document at its discretion and makes no statement about its value for implementation or deployment. Documents approved for publication by the RFC Editor are not candidates for any level of Internet Standard; see Section 2 of RFC 7841.

Information about the current status of this document, any errata, and how to provide feedback on it may be obtained at <https://www.rfc-editor.org/info/rfc9361>.

### Copyright Notice

Copyright (c) 2023 IETF Trust and the persons identified as the document authors. All rights reserved.

This document is subject to BCP 78 and the IETF Trust's Legal Provisions Relating to IETF Documents (<https://trustee.ietf.org/license-info>) in effect on the date of publication of this document. Please review these documents carefully, as they describe your rights and restrictions with respect to this document.

## Table of Contents

1. Introduction
2. Terminology
3. Glossary
4. Architecture
  - 4.1. Sunrise Period
  - 4.2. Trademark Claims Period
  - 4.3. Interfaces
    - 4.3.1. hv
    - 4.3.2. vd
    - 4.3.3. dy
    - 4.3.4. tr
    - 4.3.5. ry
    - 4.3.6. dr
    - 4.3.7. yd
    - 4.3.8. dv
    - 4.3.9. vh
    - 4.3.10. vs
    - 4.3.11. sy
    - 4.3.12. sr
    - 4.3.13. vc
    - 4.3.14. cy
    - 4.3.15. cr
5. Process Descriptions
  - 5.1. Bootstrapping
    - 5.1.1. Bootstrapping for Registries
      - 5.1.1.1. Credentials
      - 5.1.1.2. IP Addresses for Access Control
      - 5.1.1.3. ICANN TMCH Trust Anchor

- 5.1.1.4. TMDB PGP Key
- 5.1.2. Bootstrapping for Registrars
  - 5.1.2.1. Credentials
  - 5.1.2.2. IP Addresses for Access Control
  - 5.1.2.3. ICANN TMCH Trust Anchor
  - 5.1.2.4. TMDB PGP Key
- 5.2. Sunrise Period
  - 5.2.1. Domain Name Registration
  - 5.2.2. Sunrise Domain Name Registration by Registries
  - 5.2.3. TMDB Sunrise Services for Registries
    - 5.2.3.1. SMD Revocation List
    - 5.2.3.2. TMV Certificate Revocation List (CRL)
    - 5.2.3.3. Notice of Registered Domain Names (NORDN)
  - 5.2.4. Sunrise Domain Name Registration by Registrars
  - 5.2.5. TMDB Sunrise Services for Registrars
- 5.3. Trademark Claims Period
  - 5.3.1. Domain Registration
  - 5.3.2. Trademark Claims Domain Name Registration by Registries
  - 5.3.3. TMDB Trademark Claims Services for Registries
    - 5.3.3.1. Domain Name Label (DNL) List
    - 5.3.3.2. Notice of Registered Domain Names (NORDN)
  - 5.3.4. Trademark Claims Domain Name Registration by Registrars
  - 5.3.5. TMDB Trademark Claims Services for Registrars
    - 5.3.5.1. Claims Notice Information Service (CNIS)
- 5.4. Qualified Launch Program (QLP) Period
  - 5.4.1. Domain Registration
  - 5.4.2. TMDB QLP Services for Registries
    - 5.4.2.1. Sunrise List (SURL)
- 6. Data Format Descriptions
  - 6.1. Domain Name Label (DNL) List

- 6.2. [SMD Revocation List](#)
- 6.3. [List of Registered Domain Names \(LORDN\) File](#)
  - 6.3.1. [LORDN Log File](#)
    - 6.3.1.1. [LORDN Log Result Codes](#)
- 6.4. [Signed Mark Data \(SMD\) File](#)
- 6.5. [Trademark Claims Notice \(TCN\)](#)
- 6.6. [Sunrise List \(SURL\)](#)
- 7. [Formal Syntax](#)
  - 7.1. [Trademark Claims Notice \(TCN\)](#)
- 8. [IANA Considerations](#)
- 9. [Security Considerations](#)
- 10. [Privacy Considerations](#)
- 11. [References](#)
  - 11.1. [Normative References](#)
  - 11.2. [Informative References](#)

[Acknowledgements](#)

[Author's Address](#)

## 1. Introduction

Domain Name Registries may operate in special modes for certain periods of time, enabling Trademark Holders to protect their rights during the introduction of a Top-Level Domain (TLD).

Along with the introduction of new generic TLDs (gTLDs), two special modes came into effect:

- **Sunrise Period:** The Sunrise Period allows Trademark Holders an advance opportunity to register domain names corresponding to their marks before names are generally available to the public.
- **Trademark Claims Period:** The Trademark Claims Period follows the Sunrise Period and runs for at least the first 90 days of an initial operating period of general registration. During the Trademark Claims Period, anyone attempting to register a domain name matching a mark that is recorded in the ICANN Trademark Clearinghouse (TMCH) will receive a notification displaying the relevant mark information.

This document describes the requirements, the architecture, and the interfaces between the ICANN TMCH and Domain Name Registries (called "Registries" in the rest of the document), as well as between the ICANN TMCH and Domain Name Registrars (called "Registrars" in the rest of the document) for the provisioning and management of domain names during Sunrise and Trademark Claims Periods.

For any date and/or time indications, Coordinated Universal Time (UTC) applies.

## 2. Terminology

The key words "MUST", "MUST NOT", "REQUIRED", "SHALL", "SHALL NOT", "SHOULD", "SHOULD NOT", "RECOMMENDED", "NOT RECOMMENDED", "MAY", and "OPTIONAL" in this document are to be interpreted as described in BCP 14 [[RFC2119](#)] [[RFC8174](#)] when, and only when, they appear in all capitals, as shown here.

XML is case sensitive. Unless stated otherwise, XML specifications and examples provided in this document **MUST** be interpreted in the character case presented in order to develop a conforming implementation.

"tmNotice-1.0" is used as an abbreviation for "urn:ietf:params:xml:ns:tmNotice-1.0". The XML namespace prefix "tmNotice" is used, but implementations **MUST NOT** depend on it and instead employ a proper namespace-aware XML parser and serializer to interpret and output the XML documents.

Extensible Markup Language (XML) 1.0, as described in [[W3C.REC-xml-20081126](#)], and XML Schema notation, as described in [[W3C.REC-xmlschema-1-20041028](#)] and [[W3C.REC-xmlschema-2-20041028](#)], are used in this specification.

## 3. Glossary

In the following section, the most common terms are briefly explained:

**Backend Registry Operator:** An entity that manages (a part of) the technical infrastructure for a Registry Operator. The Registry Operator may also be the Backend Registry Operator.

**CA:** Certification Authority. See [[RFC5280](#)].

**CNIS:** Claims Notice Information Service. This service provides Trademark Claims Notices (TCNs) to Registrars.

**CRC32:** Cyclic Redundancy Check. This algorithm is used in the ISO 3309 standard and in Section 8.1.1.6.2 of ITU-T recommendation V.42.

**CRL:** Certificate Revocation List. See [[RFC5280](#)].

**CSV:** Comma-Separated Values. See [[RFC4180](#)].

**datetime:** Date and time. The date and time are specified following the standard specification "Date and Time on the Internet: Timestamps". See [\[RFC3339\]](#).

**DN:** Domain Name. See [\[RFC8499\]](#).

**DNL:** Domain Name Label. The DNL is an A-label or a Non-Reserved LDH (NR-LDH) label. See [\[RFC5890\]](#).

**DNL List:** A list of DNLs that are covered by a PRM.

**DNROID:** DN Repository Object Identifier. This identifier is assigned by the Registry to each DN object that unequivocally identifies said DN object. For example, if a new DN object is created for a name that existed in the past, the DN objects will have different DNROIDs.

**DNS:** Domain Name System. See [\[RFC8499\]](#).

**Effective Allocation:** A DN is considered effectively allocated when the DN object for the DN has been created in the SRS of the Registry and has been assigned to the effective user. A DN object in status "pendingCreate" or any other status that precedes the first time a DN is assigned to an end user is not considered an effective allocation. A DN object created internally by the Registry for subsequent delegation to another Registrant is not considered an effective allocation.

**EPP:** Extensible Provisioning Protocol. See [\[RFC8499\]](#).

**FQDN:** Fully Qualified Domain Name. See [\[RFC8499\]](#).

**HTTP:** Hypertext Transfer Protocol. See [\[RFC9110\]](#).

**HTTPS:** HTTP over TLS (Transport Layer Security). See [\[RFC9110\]](#).

**ICANN TMCH:** A central repository for information to be authenticated, stored, and disseminated, pertaining to the rights of TMHs. The ICANN TMCH is split into two functions: TMV and TMDB (see below). There could be several entities performing the TMV function but only one entity performing the TMDB function.

**ICANN TMCH-CA:** The Certification Authority (CA) for the ICANN TMCH. This CA is operated by ICANN. The public key for this CA is the trust anchor used to validate the identity of each TMV.

**IDN:** Internationalized Domain Name. See [\[RFC8499\]](#).

**Lookup Key:** A random string of up to 51 characters from the set [a-zA-Z0-9/] to be used as the lookup key by Registrars to obtain the TCN using the CNIS. Lookup keys are unique and are related to one DNL only.

**LORDN:** List of Registered Domain Names. This is the list of effectively allocated DNs matching a DNL of a PRM. Registries will upload this list to the TMDB (during the NORDN process).

**Matching Rules:** Some trademarks entitled to inclusion in the TMDB include characters that are impermissible in the DNS as a DNL. The TMV changes (using the ICANN TMCH Matching Rules [\[MatchingRules\]](#)) certain DNS-impermissible characters in a trademark into DNS-permissible equivalent characters.

- NORDN:** Notification of Registered Domain Names. This is the process by which Registries upload their recent LORDN to the TMDB.
- PGP:** Pretty Good Privacy. See [[RFC4880](#)].
- PKI:** Public Key Infrastructure. See [[RFC5280](#)].
- PRM:** Pre-Registered Mark. A mark that has been pre-registered with the ICANN TMCH.
- QLP Period:** Qualified Launch Program Period. During this optional period, a special process applies to DNs matching the Sunrise List (SURL) and/or the DNL List to ensure that TMHs are informed of a DN matching their PRM.
- Registrant:** See the definition of Registrant in [[RFC8499](#)].
- Registrar:** Domain Name Registrar. See [[RFC8499](#)].
- Registry:** Domain Name Registry, Registry Operator. See [[RFC8499](#)]. A Registry Operator is the contracting party with ICANN for the TLD.
- SMD:** Signed Mark Data. A cryptographically signed token issued by the TMV to the TMH to be used in the Sunrise Period to apply for a DN that matches a DNL of a PRM. See [[RFC7848](#)]. An SMD generated by an ICANN-approved Trademark Validator (TMV) contains both the signed token and the TMV's PKIX certificate.
- SMD File:** A file containing the SMD (see above) and some human-readable data. The latter is usually ignored in the processing of the SMD File. See [Section 6.4](#).
- SMD Revocation List:** The SMD Revocation List is used by Registries (and optionally by Registrars) during the Sunrise Period to ensure that an SMD is still valid (i.e., not revoked). The SMD Revocation List has a similar function as CRLs used in PKI.
- SRS:** Shared Registration System. See [[ICANN-GTLD-AGB-20120604](#)].
- Sunrise Period:** During this period, DNs matching a DNL of a PRM can be exclusively obtained by the respective TMHs. For DNs matching a PRM, a special process applies to ensure that TMHs are informed on the effective allocation of a DN matching their PRM.
- SURL:** Sunrise List. The list of DNLs that are covered by a PRM and are eligible for Sunrise.
- TCN:** Trademark Claims Notice, Claims Notice, Trademark Notice. A Trademark Claims Notice consists of one or more Trademark Claims and is provided to prospective Registrants of DNs.
- TCNID:** Trademark Claims Notice Identifier. An element of the Trademark Claims Notice (see above), identifying said TCN. The Trademark Claims Notice Identifier is specified in the element <tmNotice:id>.
- TLD:** Top-Level Domain Name. See [[RFC8499](#)].

**TMDB:** Trademark Clearinghouse Database. This serves as a database of the ICANN TMCH to provide information to the gTLD Registries and Registrars to support Sunrise or Trademark Claims services. There is only one TMDB in the ICANN TMCH that concentrates the information about the "verified" trademark records from the TMVs.

**TMH:** Trademark Holder. The person or organization owning rights on a mark.

**TMV:** Trademark Validator, Trademark Validation organization. An entity authorized by ICANN to authenticate and validate registrations in the TMDB, ensuring the marks qualify as registered, are court-validated marks, or are protected by statute or treaty. This entity would also be asked to ensure that proof of use of marks is provided, which can be demonstrated by furnishing a signed declaration and one specimen of current use.

**Trademark, Mark:** Marks are used to claim exclusive properties of products or services. A mark is typically a name, word, phrase, logo, symbol, design, image, or a combination of these elements. For the scope of this document, only textual marks are relevant.

**Trademark Claims, Claims:** Provides information to enhance the understanding of the trademark rights being claimed by the TMH.

**Trademark Claims Period:** During this period, a special process applies to DNs matching the DNL List to ensure that TMHs are informed of a DN matching their PRM. For DNs matching the DNL List, Registrars show a TCN to prospective Registrants that has to be acknowledged before effective allocation of the DN.

**UTC:** Coordinated Universal Time. This is maintained by the Bureau International des Poids et Mesures (BIPM). See [[RFC3339](#)].

## **4. Architecture**

### **4.1. Sunrise Period**



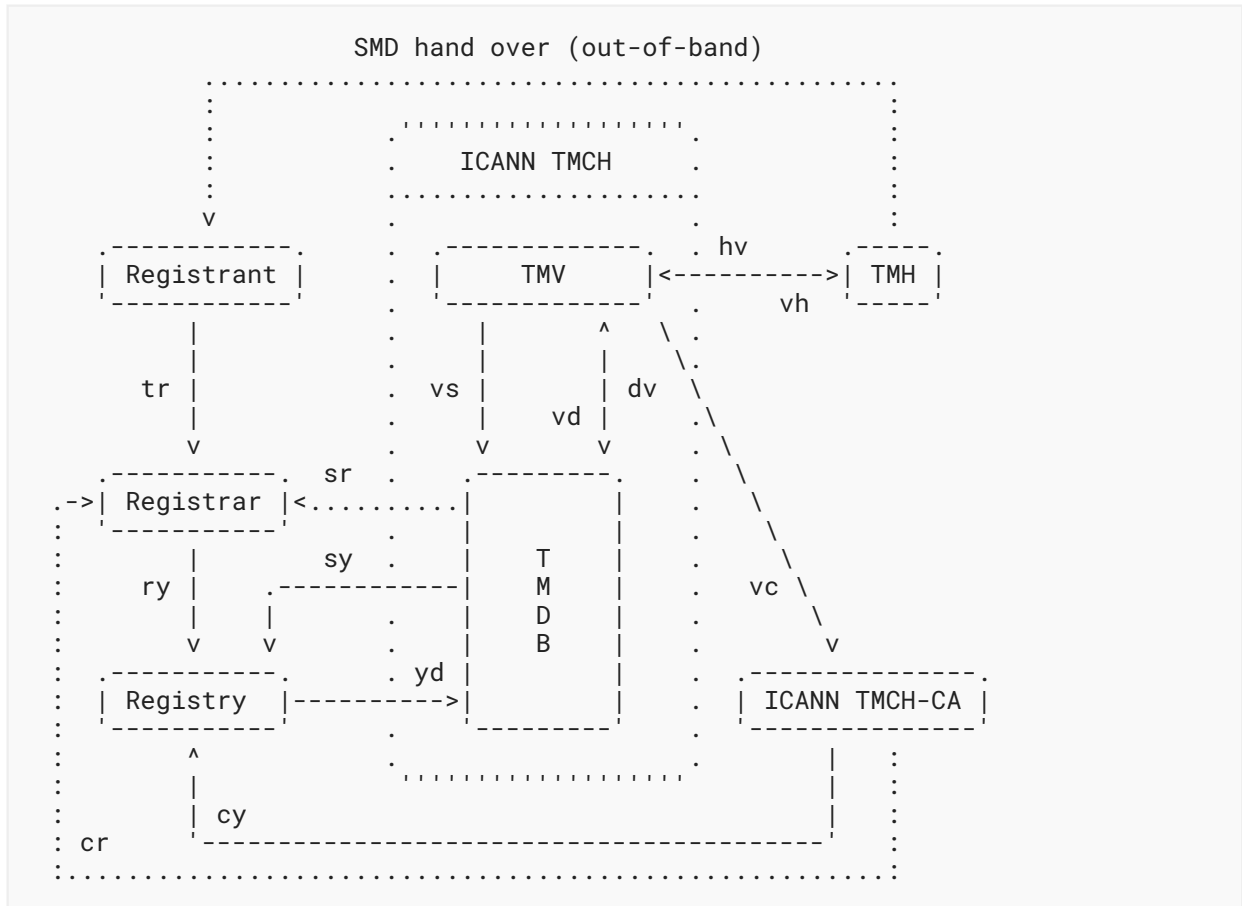

Figure 1: Architecture of the Sunrise Period

Figure 1 depicts the architecture of the Sunrise Period, including all the actors and interfaces.

## 4.2. Trademark Claims Period

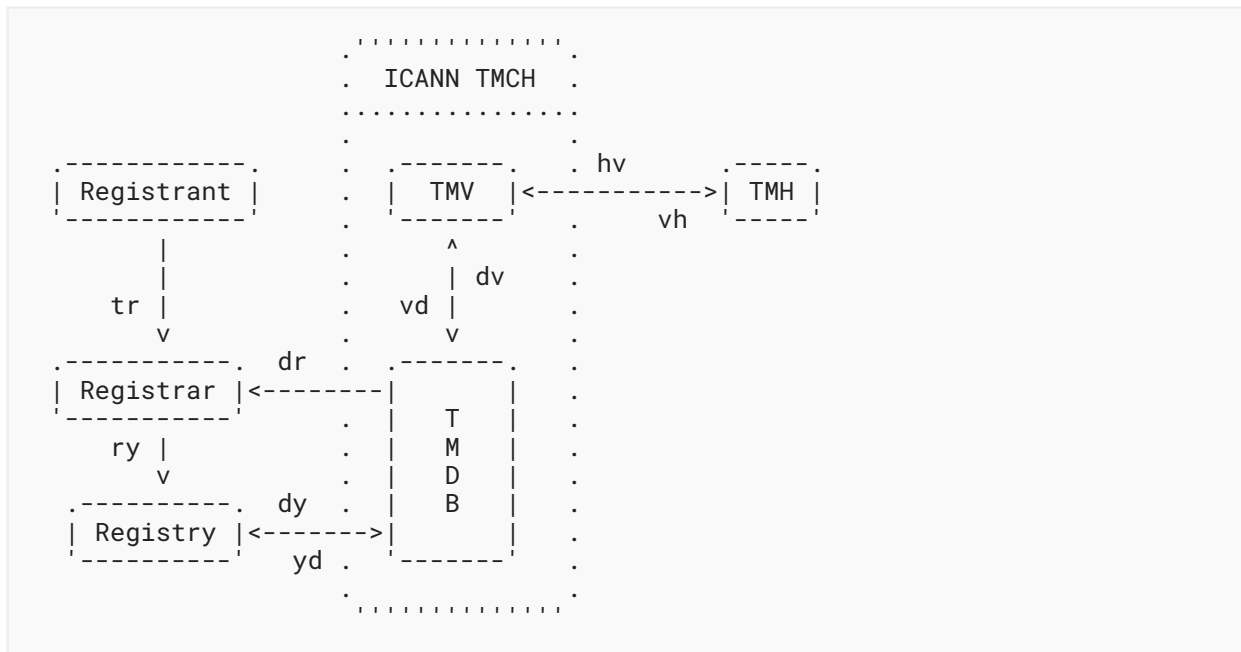

Figure 2: Architecture of the Trademark Claims Period

Figure 2 depicts the architecture of the Trademark Claims Period, including all the actors and interfaces.

### 4.3. Interfaces

The subsections below contain short descriptions of each interface to provide an overview of the architecture. More detailed descriptions of the relevant interfaces are in [Section 5](#).

#### 4.3.1. hv

The TMH registers a mark with a TMV via the hv interface.

After successful registration of the mark, the TMV makes a Signed Mark Data (SMD) File available (see [Section 6.4](#)) to the TMH to be used during the Sunrise Period.

The specifics of the hv interface are beyond the scope of this document.

#### 4.3.2. vd

After successful registration of the mark, the TMV ensures the TMDB inserts the corresponding DNLs and marks information into the database via the vd interface.

The specifics of the vd interface are beyond the scope of this document.

#### 4.3.3. dy

During the Trademark Claims Period, the Registry fetches the latest DNL List from the TMDB via the dy interface at regular intervals. The protocol used on the dy interface is HTTPS.

This interface is not relevant during the Sunrise Period.

#### **4.3.4. tr**

The Registrant communicates with the Registrar via the tr interface.

The specifics of the tr interface are beyond the scope of this document.

#### **4.3.5. ry**

The Registrar communicates with the Registry via the ry interface. The ry interfaces are typically implemented in EPP.

#### **4.3.6. dr**

During the Trademark Claims Period, the Registrar fetches the TCN from the TMDB (to be displayed to the Registrant via the tr interface) via the dr interface. The protocol used for fetching the TCN is HTTPS.

This interface is not relevant during the Sunrise Period.

#### **4.3.7. yd**

During the Sunrise Period, the Registry notifies the TMDB via the yd interface of all DNs effectively allocated.

During the Trademark Claims Period, the Registry notifies the TMDB via the yd interface of all DNs effectively allocated that matched an entry in the DNL List that the Registry previously downloaded during the creation of the DN.

The protocol used on the yd interface is HTTPS.

#### **4.3.8. dv**

The TMDB notifies the TMV via the dv interface of all effectively allocated DNs that match a mark registered by that TMV.

The specifics of the dv interface are beyond the scope of this document.

#### **4.3.9. vh**

The TMV notifies the TMH via the vh interface after an effectively allocated DN matches a PRM of this THM.

The specifics of the vh interface are beyond the scope of this document.

#### **4.3.10. vs**

The TMV requests to add revoked SMDs to the SMD Revocation List at the TMDB.

The specifics of the vs interface are beyond the scope of this document.

This interface is not relevant during the Trademark Claims Period.

**4.3.11. sy**

During the Sunrise Period, the Registry fetches the most recent SMD Revocation List from the TMDB via the sy interface in regular intervals. The protocol used on the sy interface is HTTPS.

This interface is not relevant during the Trademark Claims Period.

**4.3.12. sr**

During the Sunrise Period, the Registrar may fetch the most recent SMD Revocation List from the TMDB via the sr interface. The protocol used on the sr interface is the same as on the sy interface (see above), i.e., HTTPS.

This interface is not relevant during the Trademark Claims Period.

**4.3.13. vc**

The TMV registers its public key and requests to revoke an existing key with the ICANN TMCH-CA over the vc interface.

The specifics of the vc interface are beyond the scope of this document, but it involves personal communication between the operators of the TMV and the operators of the ICANN TMCH-CA.

This interface is not relevant during the Trademark Claims Period.

**4.3.14. cy**

During the Sunrise Period, the Registry fetches the most recent TMV CRL file from the ICANN TMCH-CA via the cy interface at regular intervals. The TMV CRL is used for validation of TMV certificates. The protocol used on the cy interface is HTTPS.

This interface is not relevant during the Trademark Claims Period.

**4.3.15. cr**

During the Sunrise Period, the Registrar optionally fetches the most recent TMV CRL file from the ICANN TMCH-CA via the cr interface at regular intervals. The TMV CRL is used for validation of TMV certificates. The protocol used on the cr interface is HTTPS.

This interface is not relevant during the Trademark Claims Period.

## 5. Process Descriptions

### 5.1. Bootstrapping

#### 5.1.1. Bootstrapping for Registries

##### 5.1.1.1. Credentials

Each Registry Operator will receive authentication credentials from the TMDB to be used:

- during the Sunrise Period to fetch the SMD Revocation List from the TMDB via the sy interface ([Section 4.3.11](#)),
- during the Trademark Claims Period to fetch the DNL List from the TMDB via the dy interface ([Section 4.3.3](#)), and
- during the NORDN process to notify the LORDN to the TMDB via the yd interface ([Section 4.3.7](#)).

Note: Credentials are created per TLD and provided to the Registry Operator.

##### 5.1.1.2. IP Addresses for Access Control

Each Registry Operator **MUST** provide the TMDB with all IP addresses, which will be used to:

- fetch the SMD Revocation List via the sy interface ([Section 4.3.11](#)),
- fetch the DNL List from the TMDB via the dy interface ([Section 4.3.3](#)), and
- upload the LORDN to the TMDB via the yd interface ([Section 4.3.7](#)).

This access restriction **MAY** be applied by the TMDB in addition to HTTP Basic access authentication (see [\[RFC7617\]](#)). For credentials to be used, see [Section 5.1.1.1](#).

The TMDB **MAY** limit the number of IP addresses to be accepted per Registry Operator.

##### 5.1.1.3. ICANN TMCH Trust Anchor

Each Registry Operator **MUST** fetch the PKIX certificate [[RFC5280](#)] of the ICANN TMCH-CA (Trust Anchor) from <https://ca.icann.org/tmch.crt> to be used:

- during the Sunrise Period to validate the TMV certificates and the TMV CRL.

##### 5.1.1.4. TMDB PGP Key

The TMDB **MUST** provide each Registry Operator with the public portion of the PGP Key used by the TMDB, which is to be used:

- during the Sunrise Period to perform integrity checking of the SMD Revocation List fetched from the TMDB via the sy interface ([Section 4.3.11](#)) and
- during the Trademark Claims Period to perform integrity checking of the DNL List fetched from the TMDB via the dy interface ([Section 4.3.3](#)).

### 5.1.2. Bootstrapping for Registrars

#### 5.1.2.1. Credentials

Each ICANN-Accredited Registrar will receive authentication credentials from the TMDB to be used:

- during the Sunrise Period to (optionally) fetch the SMD Revocation List from the TMDB via the sr interface ([Section 4.3.12](#)) and
- during the Trademark Claims Period to fetch TCNs from the TMDB via the dr interface ([Section 4.3.6](#)).

#### 5.1.2.2. IP Addresses for Access Control

Each Registrar **MUST** provide the TMDB with all IP addresses, which will be used to:

- fetch the SMD Revocation List via the sr interface ([Section 4.3.12](#)) and
- fetch TCNs via the dr interface ([Section 4.3.6](#)).

This access restriction **MAY** be applied by the TMDB in addition to HTTP Basic access authentication (for credentials to be used, see [Section 5.1.2.1](#)).

The TMDB **MAY** limit the number of IP addresses to be accepted per Registrar.

#### 5.1.2.3. ICANN TMCH Trust Anchor

Registrars **MAY** fetch the PKIX certificate of the ICANN TMCH-CA (Trust Anchor) from <<https://ca.icann.org/tmch.crt>> to be used:

- during the Sunrise Period to (optionally) validate the TMV certificates and TMV CRL.

#### 5.1.2.4. TMDB PGP Key

Registrars **MUST** receive the public portion of the PGP Key used by TMDB from the TMDB administrator to be used:

- during the Sunrise Period to (optionally) perform integrity checking of the SMD Revocation List fetched from the TMDB via the sr interface ([Section 4.3.12](#)).

## 5.2. Sunrise Period

### 5.2.1. Domain Name Registration

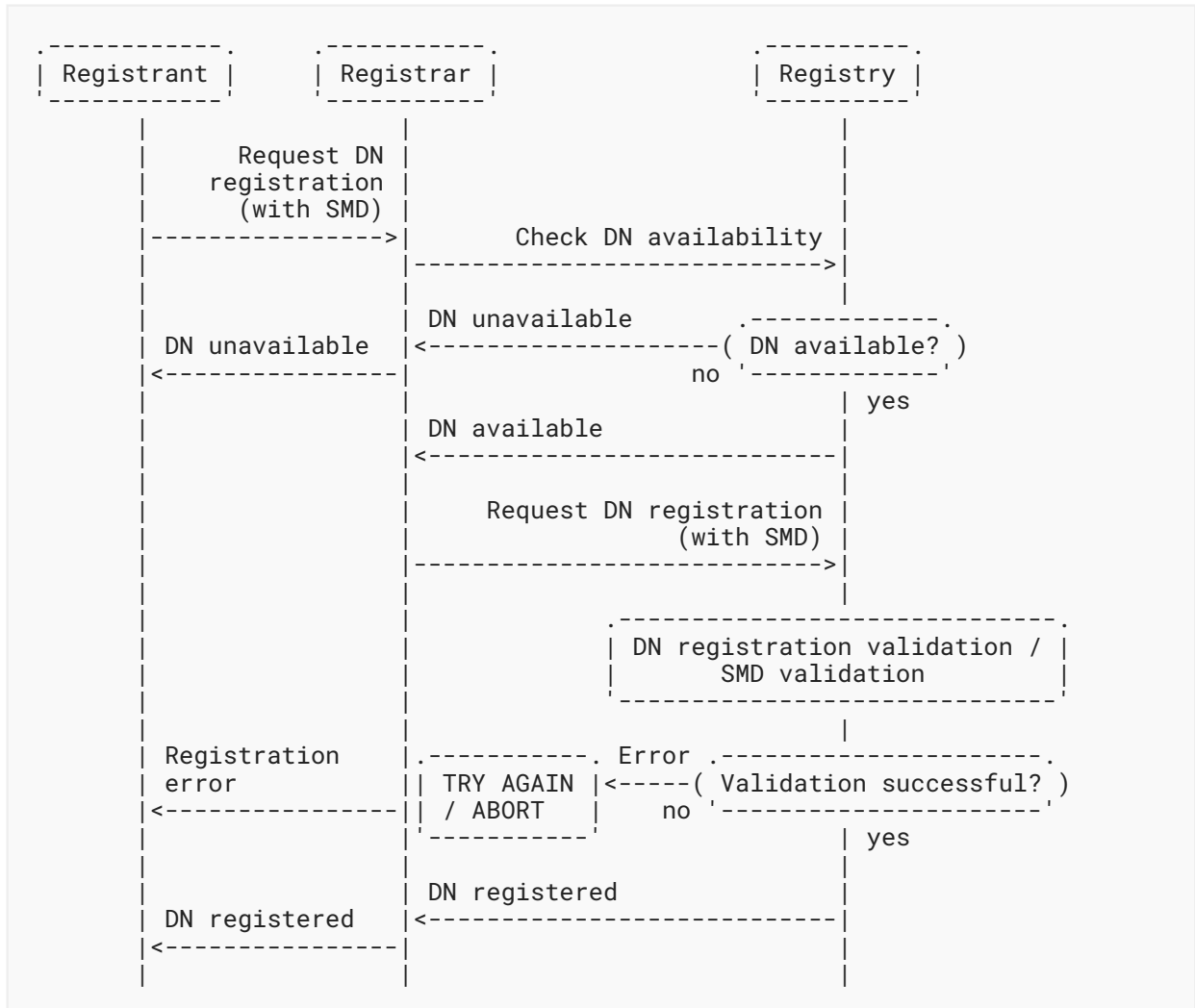

Figure 3: Domain Name Registration during the Sunrise Period

Figure 3 represents a synchronous DN registration workflow (usually called first come first served).

### 5.2.2. Sunrise Domain Name Registration by Registries

Registries **MUST** perform a minimum set of checks for verifying each DN registration during the Sunrise Period upon reception of a registration request over the ry interface (Section 4.3.5). If any of these checks fail, the Registry **MUST** abort the registration. Each of these checks **MUST** be performed before the DN is effectively allocated.

In case of asynchronous registrations (e.g., auctions), the minimum set of checks **MAY** be performed when creating the intermediate object (e.g., a DN application) used for DN registration. If the minimum set of checks is performed when creating the intermediate object (e.g., a DN application), a Registry **MAY** effectively allocate the DN without performing the minimum set of checks again.

Performing the minimum set of checks, Registries **MUST** verify that:

1. an SMD has been received from the Registrar, along with the DN registration,
2. the certificate of the TMV has been correctly signed by the ICANN TMCH-CA (the certificate of the TMV is contained within the SMD),
3. the datetime when the validation is done is within the validity period of the TMV certificate,
4. the certificate of the TMV is not listed in the TMV CRL file specified in the CRL distribution point of the TMV certificate,
5. the signature of the SMD (signed with the TMV certificate) is valid,
6. the datetime when the validation is done is within the validity period of the SMD based on `<smd:notBefore>` and `<smd:notAfter>` elements,
7. the SMD has not been revoked, i.e., is not contained in the SMD Revocation List, and
8. the leftmost DNL of the DN being effectively allocated matches one of the label (`<mark:label>`) elements in the SMD. For example, if the DN "xn--mgbachtv.xn--mgbh0fb" is being effectively allocated, the leftmost DNL would be "xn--mgbachtv".

These procedures apply to all DN effective allocations at the second level, as well as to all other levels subordinate to the TLD that the Registry accepts registrations for.

### 5.2.3. TMDB Sunrise Services for Registries

#### 5.2.3.1. SMD Revocation List

A new SMD Revocation List **MUST** be published by the TMDB twice a day, by 00:00:00 and 12:00:00 UTC.

Registries **MUST** refresh the latest version of the SMD Revocation List at least once every 24 hours.

Note: The SMD Revocation List will be the same regardless of the TLD. If a Backend Registry Operator manages the infrastructure of several TLDs, the Backend Registry Operator could refresh the SMD Revocation List once every 24 hours, and the SMD Revocation List could be used for all the TLDs managed by the Backend Registry Operator.



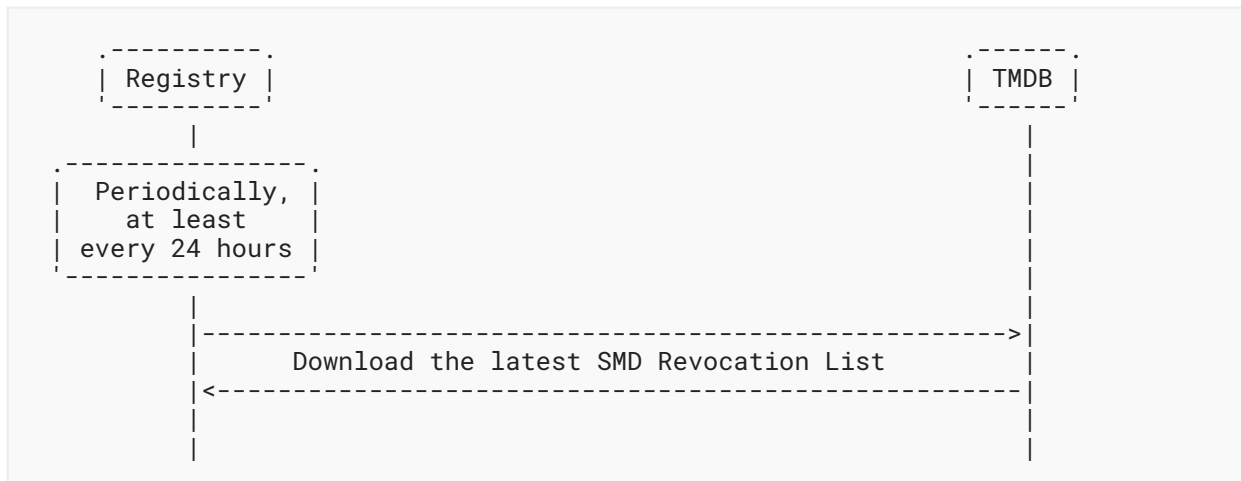

Figure 4: Update of the SMD Revocation List

Figure 4 depicts the process of downloading the latest SMD Revocation List initiated by the Registry.

#### 5.2.3.2. TMV Certificate Revocation List (CRL)

Registries **MUST** refresh their local copy of the TMV CRL file at least once every 24 hours using the CRL distribution point specified in the TMV certificate.

Operationally, the TMV CRL file and CRL distribution point are the same for all TMVs and (at publication of this document) are located at <<http://crl.icann.org/tmch.crl>>.

Note: The TMV CRL file will be the same regardless of the TLD. If a Backend Registry Operator manages the infrastructure of several TLDs, the Backend Registry Operator could refresh the TMV CRL file once every 24 hours, and the TMV CRL file could be used for all the TLDs managed by the Backend Registry Operator.

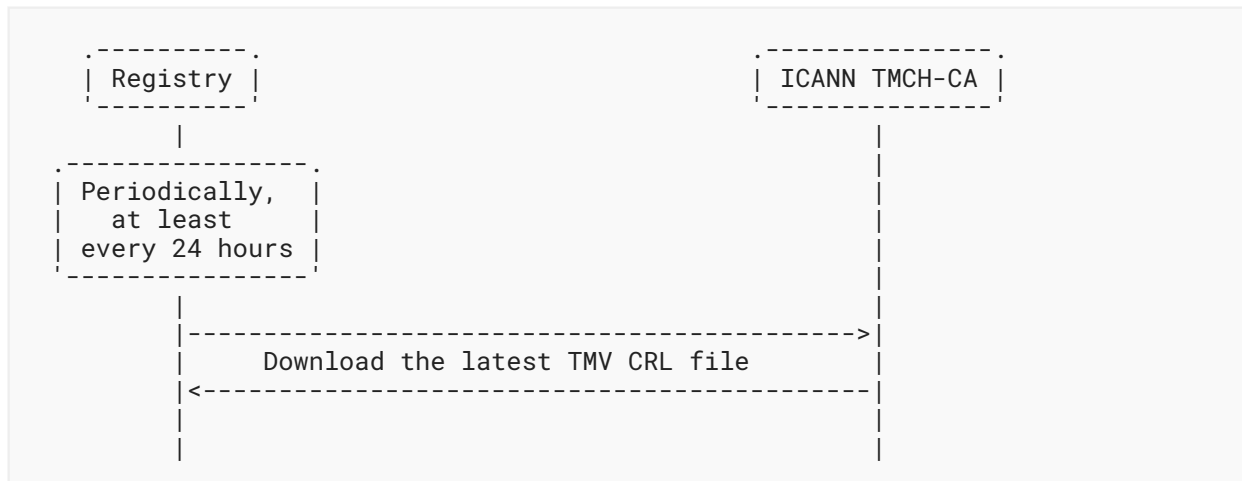

Figure 5: Update of the TMV CRL File

Figure 5 depicts the process of downloading the latest TMV CRL file initiated by the Registry.

### 5.2.3.3. Notice of Registered Domain Names (NORDN)

The Registry **MUST** send a LORDN file containing DNs effectively allocated to the TMDB (over the yd interface; see [Section 4.3.7](#)).

The effective allocation of a DN **MUST** be reported by the Registry to the TMDB within 26 hours of the effective allocation of such DN.

The Registry **MUST** create and upload a LORDN file in case there are effective allocations in the SRS that have not been successfully reported to the TMDB in a previous LORDN file.

Based on the timers used by TMVs and the TMDB, the **RECOMMENDED** maximum frequency to upload LORDN files from the Registries to the TMDB is every 3 hours.

It is **RECOMMENDED** that Registries try to upload at least two LORDN files per day to the TMDB, with enough time in between, in order to have time to fix problems reported in the LORDN file.

The Registry **SHOULD** upload a LORDN file only when the previous LORDN file has been processed by the TMDB and the related LORDN Log file has been downloaded and processed by the Registry.

The Registry **MUST** upload LORDN files for DNs that are effectively allocated during the Sunrise or Trademark Claims Periods (same applies to DNs that are effectively allocated using applications created during the Sunrise or Trademark Claims Periods in case of using asynchronous registrations).

The yd interface ([Section 4.3.7](#)) **MUST** support at least one (1) and **MAY** support up to ten (10) concurrent connections from each IP address registered by a Registry Operator to access the service.

The TMDB **MUST** process each uploaded LORDN file and make the related log file available for Registry download within 30 minutes of the finalization of the upload.

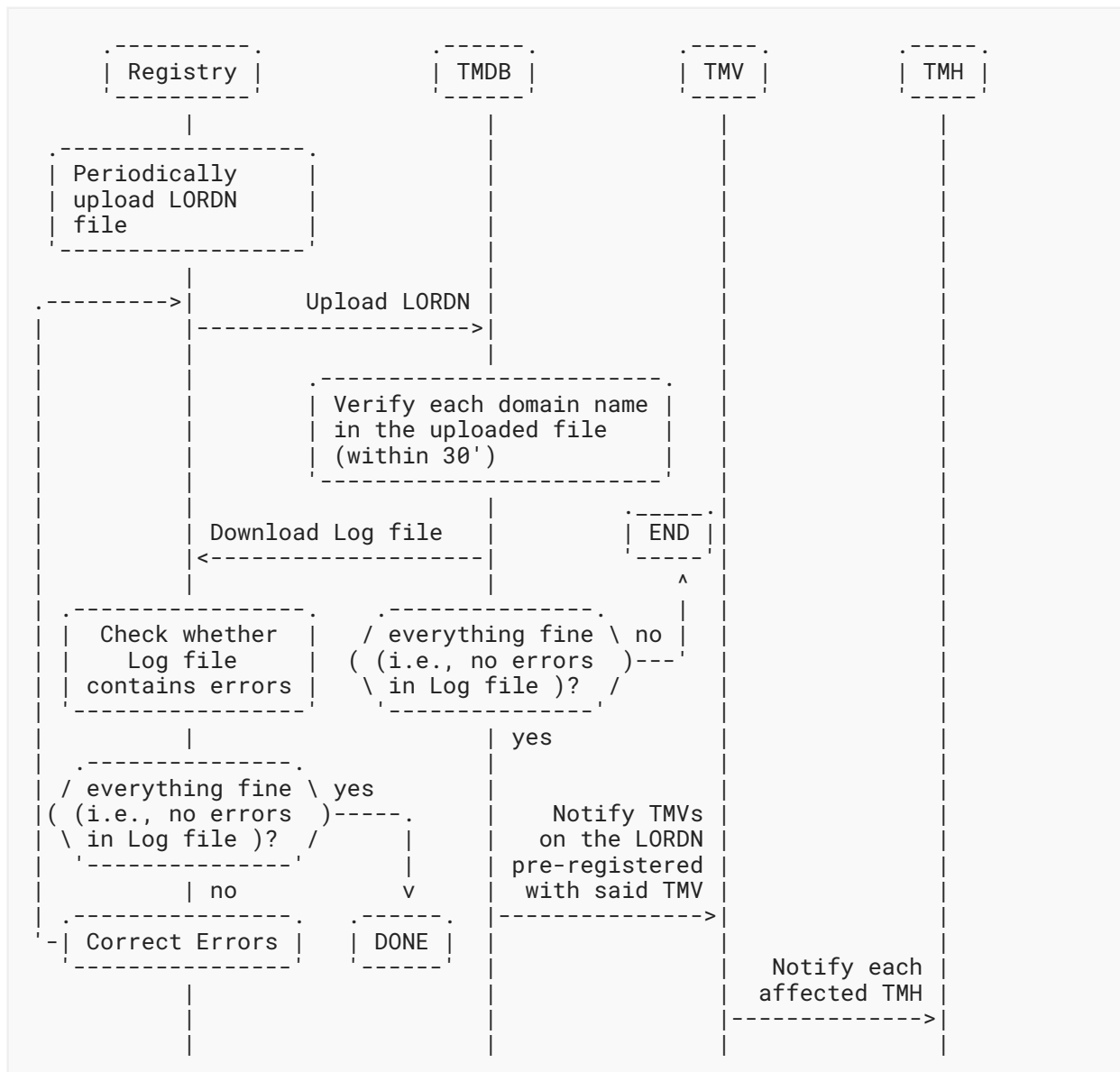

Figure 6: Notification of the Registered Domain Name

Figure 6 depicts the process to notify the TMH of Registered Domain Names.

The format used for the LORDN is described in [Section 6.3](#).

#### 5.2.4. Sunrise Domain Name Registration by Registrars

Registrars **MAY** choose to perform the checks for verifying DN registrations, as performed by the Registries (see [Section 5.2.2](#)) before sending the command to register a DN.

### 5.2.5. TMDB Sunrise Services for Registrars

The processes described in Sections 5.2.3.1 and 5.2.3.2 are also available for Registrars to optionally validate the SMDs received.

## 5.3. Trademark Claims Period

### 5.3.1. Domain Registration

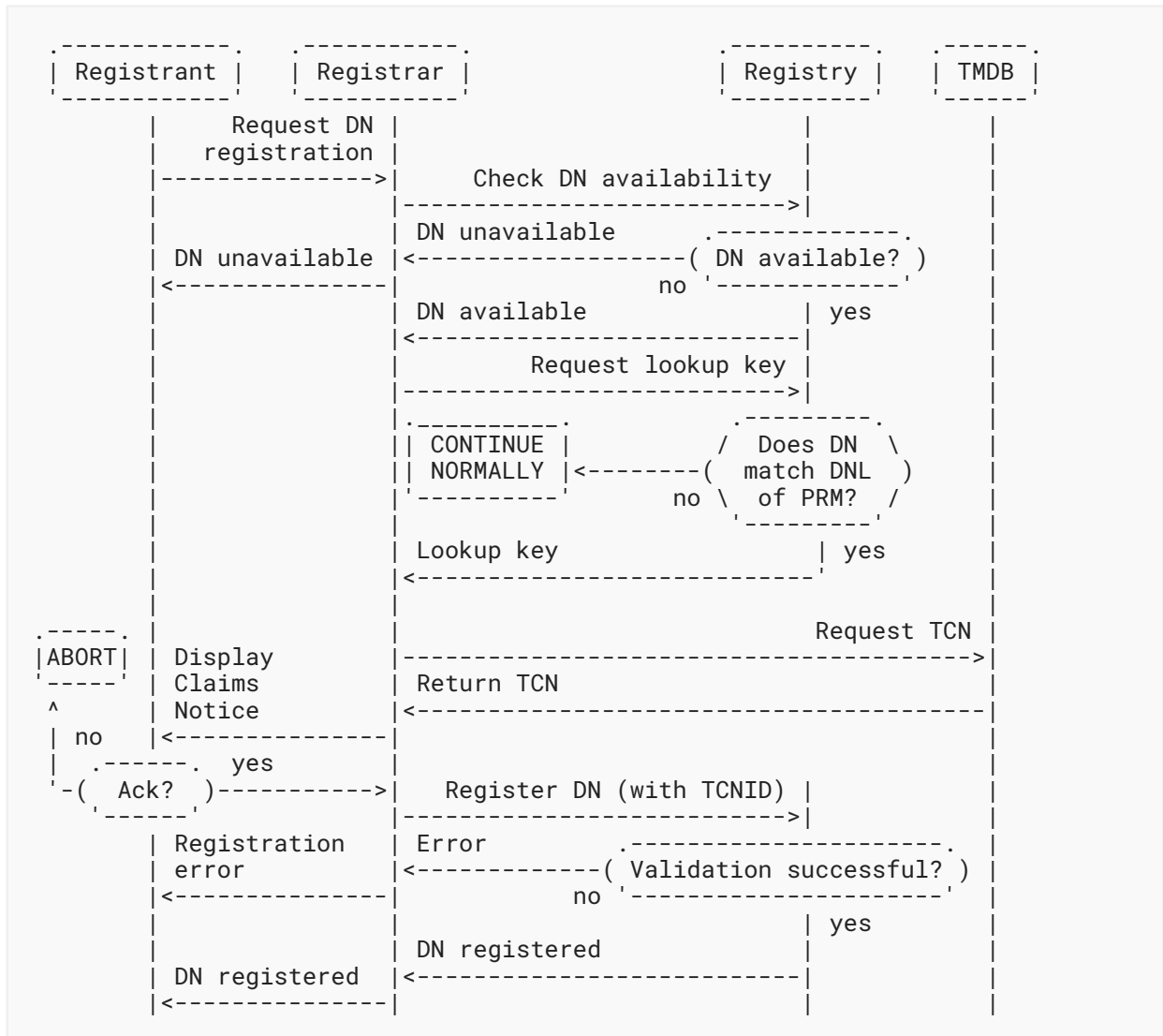

Figure 7: Domain Name Registration during the Trademark Claims Period

Figure 7 represents a synchronous DN registration workflow (usually called first come first served).

### 5.3.2. Trademark Claims Domain Name Registration by Registries

During the Trademark Claims Period, Registries perform two main functions:

- Registries **MUST** provide Registrars (over the ry interface; see [Section 4.3.5](#)) the lookup key used to retrieve the TCNs for DNs that match the DNL List.
- Registries **MUST** provide the lookup key only when queried about a specific DN.

In the following instances, a minimum set of checks are described:

- For each DN matching a DNL of a PRM, Registries **MUST** perform a minimum set of checks for verifying DN registrations during the Trademark Claims Period upon reception of a registration request over the ry interface ([Section 4.3.5](#)). If any of these checks fail, the Registry **MUST** abort the registration. Each of these checks **MUST** be performed before the DN is effectively allocated.
- In case of asynchronous registrations (e.g., auctions), the minimum set of checks **MAY** be performed when creating the intermediate object (e.g., a DN application) used for DN effective allocation. If the minimum set of checks is performed when creating the intermediate object (e.g., a DN application), a Registry **MAY** effectively allocate the DN without performing the minimum set of checks again.
- Performing the minimum set of checks, Registries **MUST** verify that:
  1. The TCNID (<tmNotice:id>), expiration datetime (<tmNotice:notAfter>), and acceptance datetime of the TCN have been received from the Registrar, along with the DN registration.  
If the three elements mentioned above are not provided by the Registrar for a DN matching a DNL of a PRM, but the DNL was inserted (or reinserted) for the first time into the DNL List less than 24 hours ago, the registration **MAY** continue without this data, and the tests listed below are not required to be performed.
  2. The TCN has not expired (according to the expiration datetime sent by the Registrar).
  3. The acceptance datetime is within the window of time defined by ICANN policy. In the gTLD round of 2012, Registrars verified that the acceptance datetime was less than or equal to 48 hours in the past, as there were no defined ICANN policies at that time. Implementers should be aware that ICANN policy may define this value in the future.
  4. The TCN Checksum is computed using the leftmost DNL of the DN being effectively allocated, the expiration datetime provided by the Registrar, and the TMDB Notice Identifier extracted from the TCNID provided by the Registrar. Verify that the computed TCN Checksum matches the TCN Checksum present in the TCNID. For example, if the DN "xn--mgbachtv.xn--mgbh0fb" is being effectively allocated, the leftmost DNL would be "xn--mgbachtv".

These procedures apply to all DN registrations at the second level, as well as to all other levels subordinate to the TLD that the Registry accepts registrations for.

### 5.3.3. TMDB Trademark Claims Services for Registries

#### 5.3.3.1. Domain Name Label (DNL) List

A new DNL List **MUST** be published by the TMDB twice a day, by 00:00:00 and 12:00:00 UTC.

Registries **MUST** refresh the latest version of the DNL List at least once every 24 hours.

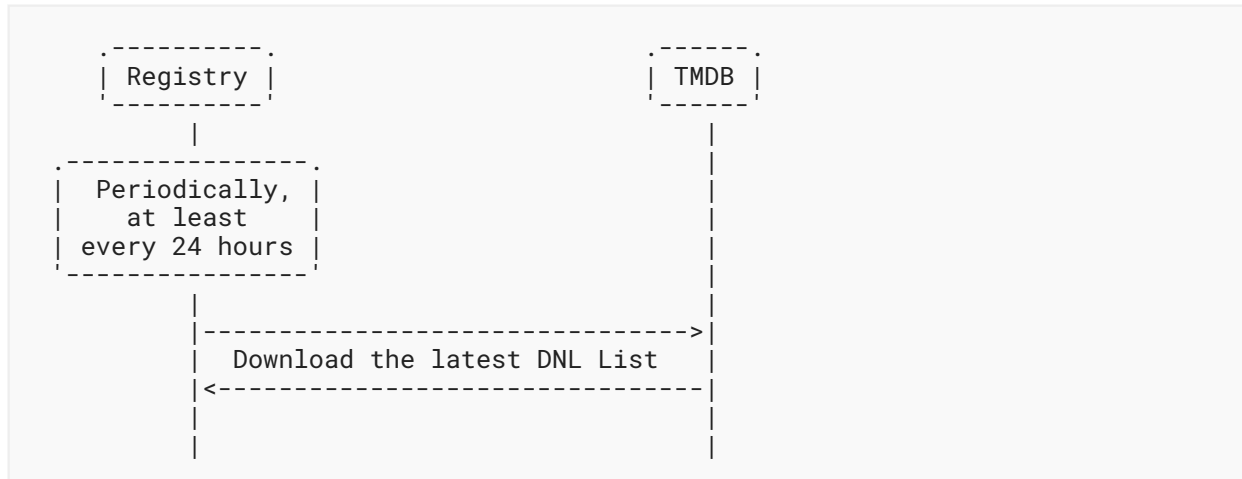

Figure 8: Update of the DNL List

Figure 8 depicts the process of downloading the latest DNL List initiated by the Registry.

Note: The DNL List will be the same regardless of the TLD. If a Backend Registry Operator manages the infrastructure of several TLDs, the Backend Registry Operator could refresh the DNL List once every 24 hours, and the DNL List could be used for all the TLDs managed by the Backend Registry Operator.

#### 5.3.3.2. Notice of Registered Domain Names (NORDN)

The NORDN process during the Trademark Claims Period is almost the same as during the Sunrise Period, as defined in [Section 5.2.3.3](#); the difference is that only registrations subject to a Trademark Claim (i.e., at registration time, the name appeared in the current DNL List downloaded by the Registry Operator) are included in the LORDN.

#### 5.3.4. Trademark Claims Domain Name Registration by Registrars

For each DN matching a DNL of a PRM, Registrars **MUST** perform the following steps:

1. Use the lookup key received from the Registry to obtain the TCN from the TMDB using the dr interface ([Section 4.3.6](#)). Registrars **MUST** only query for the lookup key of a DN that is available for registration.
2. Present the TCN to the Registrant, as described in Exhibit A of [\[RPM-Requirements\]](#).

3. Ask the Registrant for acknowledgement, i.e., the Registrant **MUST** consent with the TCN, before any further processing. (The transmission of a TCNID to the Registry over the ry interface ([Section 4.3.5](#)) implies that the Registrant has expressed their consent with the TCN.)
4. Perform the minimum set of checks for verifying DN registrations. If any of these checks fail, the Registrar **MUST** abort the DN registration. Each of these checks **MUST** be performed before the registration is sent to the Registry. Performing the minimum set of checks, Registrars **MUST** verify the following:
  - a. The datetime when the validation is done is within the TCN validity based on the <tmNotice:notBefore> and <tmNotice:notAfter> elements.
  - b. The leftmost DNL of the DN being effectively allocated matches the label (<tmNotice:label>) element in the TCN. For example, if the DN "xn--mgbachtv.xn--mgbh0fb" is being effectively allocated, the leftmost DNL would be "xn--mgbachtv".
  - c. The Registrant has acknowledged (expressed their consent with) the TCN.
5. Record the date and time when the registrant acknowledged the TCN.
6. Send the registration to the Registry (via the ry interface; see [Section 4.3.5](#)) and include the following information:
  - TCNID (<tmNotice:id>)
  - Expiration date of the TCN (<tmNotice:notAfter>)
  - Acceptance datetime of the TCN

Currently, TCNs are generated twice a day by the TMDB. The expiration date (<tmNotice:notAfter>) of each TCN **MUST** be set to a value defined by ICANN policy. In the gTLD round of 2012, the TMDB set the expiration value to 48 hours into the future, as there were no defined ICANN policies at that time. Implementers should be aware that ICANN policy may define this value in the future.

Registrars **SHOULD** implement a cache of TCNs to minimize the number of queries sent to the TMDB. A cached TCN **MUST** be removed from the cache after the expiration date of the TCN, as defined by <tmNotice:notAfter>.

The TMDB **MAY** implement rate limiting as one of the protection mechanisms to mitigate the risk of performance degradation.

### 5.3.5. TMDB Trademark Claims Services for Registrars

#### 5.3.5.1. Claims Notice Information Service (CNIS)

The TCNs are provided by the TMDB online and are fetched by the Registrar via the dr interface ([Section 4.3.6](#)).

To get access to the TCNs, the Registrar needs the credentials provided by the TMDB ([Section 5.1.2.1](#)) and the lookup key received from the Registry via the ry interface ([Section 4.3.5](#)). The dr interface ([Section 4.3.6](#)) uses HTTPS with Basic access authentication.

The dr interface ([Section 4.3.6](#)) **MAY** support up to ten (10) concurrent connections from each Registrar.

The URL of the dr interface ([Section 4.3.6](#)) is:

```
https://<tmdb-domain-name>/cnis/<lookupkey>.xml
```

Note that the "lookupkey" may contain slash characters ("/"). The slash character is part of the URL path and **MUST NOT** be escaped when requesting the TCN.

The TLS certificate (HTTPS) used on the dr interface ([Section 4.3.6](#)) **MUST** be signed by a well-know public CA. Registrars **MUST** perform the certification path validation described in [Section 6](#) of [[RFC5280](#)]. Registrars will be authenticated in the dr interface using HTTP Basic access authentication. The dr interface ([Section 4.3.6](#)) **MUST** support HTTPS keep-alive and **MUST** maintain the connection for up to 30 minutes.

## 5.4. Qualified Launch Program (QLP) Period

### 5.4.1. Domain Registration

During the **OPTIONAL** Qualified Launch Program (QLP) Period (see [[QLP-Addendum](#)]), effective allocations of DNs to third parties could require that Registries and Registrars provide Sunrise and/or Trademark Claims services. If required, Registries and Registrars **MUST** provide Sunrise and/or Trademark Claims services, as described in [Sections 5.2](#) and [5.3](#).

The effective allocation scenarios are as follows:

- If the leftmost DNL of the DN being effectively allocated (QLP Name in this section) matches a DNL in the SURL and an SMD is provided, then Registries **MUST** provide Sunrise Services (see [Section 5.2](#)), and the DN **MUST** be reported in a Sunrise LORDN file during the QLP Period. For example, if the DN "xn--mgbachtv.xn--mgbh0fb" is being effectively allocated, the leftmost DNL would be "xn--mgbachtv".
- If the QLP Name matches a DNL in the SURL but does not match a DNL in the DNL List and an SMD is **NOT** provided (see [Section 2.2](#) of [[QLP-Addendum](#)]), then the DN **MUST** be reported in a Sunrise LORDN file using the special SMD-id "99999-99999" during the QLP Period.
- If the QLP Name matches a DNL in the SURL and also matches a DNL in the DNL List and an SMD is **NOT** provided (see [Section 2.2](#) of [[QLP-Addendum](#)]), then Registries **MUST** provide Trademark Claims services (see [Section 5.3](#)), and the DN **MUST** be reported in a Trademark Claims LORDN file during the QLP Period.
- If the QLP Name matches a DNL in the DNL List but does not match a DNL in the SURL, then Registries **MUST** provide Trademark Claims services (see [Section 5.3](#)), and the DN **MUST** be reported in a Trademark Claims LORDN file during the QLP Period.

The following table lists all the effective allocation scenarios during a QLP Period:



QLP Name Match in the SURL	QLP Name Match in the DNL List	SMD Was Provided by the Potential Registrant	Registry MUST Provide Sunrise or Trademark Claims Services	Registry MUST Report DN Registration in <type> LORDN File
Y	Y	Y	Sunrise	Sunrise
Y	N	Y	Sunrise	Sunrise
N	Y	--	Trademark Claims	Trademark Claims
N	N	--	--	--
Y	Y	N (see Section 2.2 of [QLP-Addendum])	Trademark Claims	Trademark Claims
Y	N	N (see Section 2.2 of [QLP-Addendum])	--	Sunrise (using special SMD-id)

Table 1: QLP Effective Allocation Scenarios

The TMDB **MUST** provide the following services to Registries during a QLP Period:

- SMD Revocation List (see [Section 5.2.3.1](#))
- NORDN (see [Section 5.2.3.3](#))
- DNL List (see [Section 5.3.3.1](#))
- Sunrise List (SURL) (see [Section 5.4.2.1](#))

The TMDB **MUST** provide the following services to Registrars during a QLP Period:

- SMD Revocation List (see [Section 5.2.3.1](#))
- CNIS (see [Section 5.3.5.1](#))

## 5.4.2. TMDB QLP Services for Registries

### 5.4.2.1. Sunrise List (SURL)

A new SURL **MUST** be published by the TMDB twice a day, by 00:00:00 and 12:00:00 UTC.

Registries offering the **OPTIONAL** QLP Period **MUST** refresh the latest version of the SURL at least once every 24 hours.

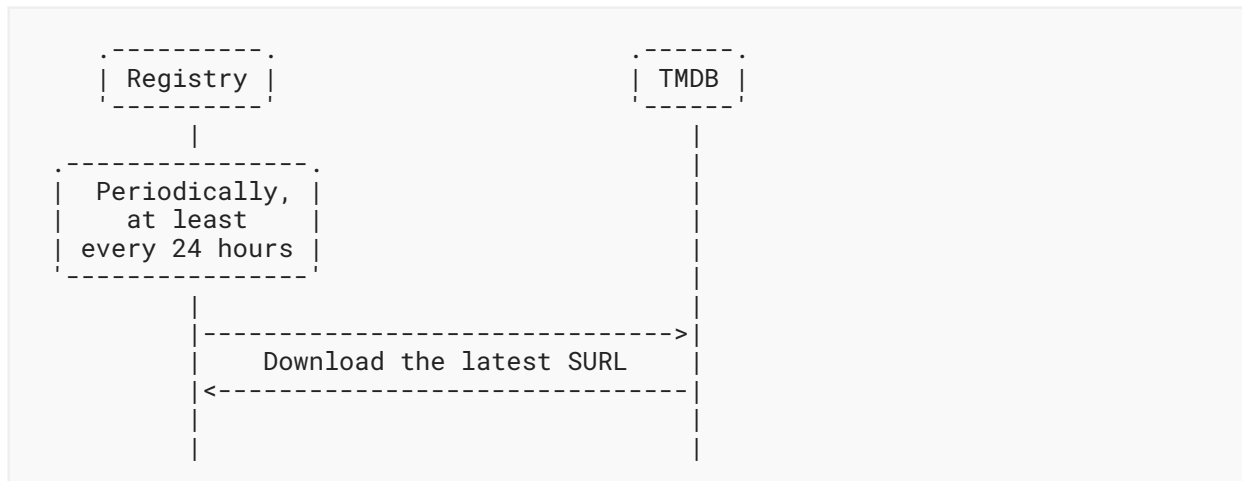

Figure 9: Update of the SURL

Figure 9 depicts the process of downloading the latest SURL initiated by the Registry.

Note: The SURL will be the same regardless of the TLD. If a Backend Registry Operator manages the infrastructure of several TLDs, the Backend Registry Operator could refresh the SURL once every 24 hours, and the SURL could be used for all the TLDs managed by the Backend Registry Operator.

## 6. Data Format Descriptions

### 6.1. Domain Name Label (DNL) List

This section defines the format of the list containing every DNL that matches a Pre-Registered Mark (PRM). The list is maintained by the TMDB and downloaded by Registries in regular intervals (see [Section 5.3.3.1](#)). The Registries use the DNL List during the Trademark Claims Period to check whether a requested DN matches a DNL of a PRM.

The DNL List contains all the DNLs covered by a PRM present in the TMDB at the datetime that the DNL List is generated.

The DNL List is contained in a CSV-formatted file that has the following structure:

- first line: <version>,<DNL List creation datetime>

Where:

- <version>: version of the file. This field **MUST** be 1.
  - <DNL List creation datetime>: date and time in UTC that the DNL List was created.
- second line: a header line, as specified in [[RFC4180](#)]

With the header names as follows:

DNL,lookup-key,insertion-datetime

- One or more lines with: <DNL>,<lookup key>,<DNL insertion datetime>

Where:

- <DNL>: a Domain Name Label covered by a PRM.
- <lookup key>: lookup key that the Registry **MUST** provide to the Registrar. The lookup key has the following format: <YYYY><MM><DD><vv>/<X>/<X>/<X>/<Random bits><Sequential number>, where:
  - YYYY: year that the TCN was generated.
  - MM: zero-padded month that the TCN was generated.
  - DD: zero-padded day that the TCN was generated.
  - vv: version of the TCN; possible values are 00 and 01.
  - X: one hex character. This is the first, second, and third hex character of encoding the <Random bits> in base16, as specified in [RFC4648].
  - Random bits: 144 random bits encoded in base64url, as specified in [RFC4648].
  - Sequential number: zero-padded natural number in the range 0000000001 to 2147483647.
- <DNL insertion datetime>: datetime in UTC that the DNL was first inserted into the DNL List. The possible two values of time for inserting a DNL to the DNL List are 00:00:00 and 12:00:00 UTC.

Example of a DNL list:

```
1,2012-08-16T00:00:00.0Z
DNL,lookup-key,insertion-datetime
example,2013041500/2/6/9/rJ1NrD092vDsAzf7EQzgjX4R0000000001, \
  2010-07-14T00:00:00.0Z
another-example,2013041500/6/A/5/a1JAqG2vI2BmCv5PfUvuDkf40000000002, \
  2012-08-16T00:00:00.0Z
anotherexample,2013041500/A/C/7/rHdC4wnrWRvPY6nneCVtQhFj0000000003, \
  2011-08-16T12:00:00.0Z
```

Figure 10: Example DNL List

To provide authentication and integrity protection, the DNL List will be PGP [RFC4880] signed by the TMDB (see Section 5.1.1.4). The PGP signature of the DNL List can be found in the similar URI but with extension .sig, as shown below.

The URLs of the dy interface (Section 4.3.3) are:

- <https://<tmdb-domain-name>/dnl/dnl-latest.csv>
- <https://<tmdb-domain-name>/dnl/dnl-latest.sig>

## 6.2. SMD Revocation List

This section defines the format of the list of SMDs that have been revoked. The list is maintained by the TMDB and downloaded by Registries (and optionally by Registrars) in regular intervals (see [Section 5.2.3.1](#)). The SMD Revocation List is used during the Sunrise Period to validate SMDs received. The SMD Revocation List has a similar function as CRLs used in PKI [[RFC5280](#)].

The SMD Revocation List contains all the revoked SMDs present in the TMDB at the datetime it is generated.

The SMD Revocation List is contained in a CSV-formatted file that has the following structure:

- first line: <version>,<SMD Revocation List creation datetime>

Where:

- <version>: version of the file. This field **MUST** be 1.
- <SMD Revocation List creation datetime>: datetime in UTC that the SMD Revocation List was created.

- second line: a header line, as specified in [[RFC4180](#)]

With the header names as follows:

smd-id,insertion-datetime

- One or more lines with: <smd-id>,<revoked SMD datetime>

Where:

- <smd-id>: identifier of the SMD that was revoked.
- <revoked SMD datetime>: revocation datetime in UTC of the SMD. The possible two values of time for inserting an SMD to the SMD Revocation List are 00:00:00 and 12:00:00 UTC.

To provide integrity protection, the SMD Revocation List is PGP signed by the TMDB (see [Section 5.1.1.4](#)). The SMD Revocation List is provided by the TMDB with extension .csv. The PGP signature of the SMD Revocation List can be found in the similar URI but with extension .sig, as shown below.

The URLs of the sr interface ([Section 4.3.12](#)) and sy interface ([Section 4.3.11](#)) are:

- <https://<tmdb-domain-name>/smdrl/smdrl-latest.csv>
- <https://<tmdb-domain-name>/smdrl/smdrl-latest.sig>

Example of an SMD Revocation List:

```
1,2012-08-16T00:00:00.0Z
smd-id,insertion-datetime
2-2,2012-08-15T00:00:00.0Z
3-2,2012-08-15T00:00:00.0Z
1-2,2012-08-15T00:00:00.0Z
```

Figure 11: Example SMD Revocation List

### 6.3. List of Registered Domain Names (LORDN) File

This section defines the format of the List of Registered Domain Names (LORDN), which is maintained by each Registry and uploaded at least daily to the TMDB. Every time there is a DN matching a DNL of a PRM, said DN is added to the LORDN, along with further information related to its registration.

The URIs of the yd interface ([Section 4.3.7](#)) used to upload the LORDN file are:

- Sunrise LORDN file:  
`https://<tmdb-domain-name>/LORDN/<TLD>/sunrise`
- Trademark Claims LORDN file:  
`https://<tmdb-domain-name>/LORDN/<TLD>/claims`

During a QLP Period, Registries **MAY** be required to upload Sunrise or Trademark Claims LORDN files. The URIs of the yd interface used to upload LORDN files during a QLP Period are:

- Sunrise LORDN file (during QLP Period):  
`https://<tmdb-domain-name>/LORDN/<TLD>/sunrise/qlp`
- Trademark Claims LORDN file (during a QLP Period):  
`https://<tmdb-domain-name>/LORDN/<TLD>/claims/qlp`

The yd interface ([Section 4.3.7](#)) returns the following HTTP status codes after an HTTP POST request method is received:

- The interface provides an HTTP/202 status code if the interface was able to receive the LORDN file and the syntax of the LORDN file is correct.

The interface provides the LORDN Transaction Identifier in the HTTP Entity-body that would be used by the Registry to download the LORDN Log file. The LORDN Transaction Identifier is a zero-padded natural number in the range 00000000000000000001 to 9223372036854775807.

The TMDB uses the <LORDN creation datetime> element of the LORDN file as a unique client-side identifier. If a LORDN file with the same <LORDN creation datetime> of a previously sent LORDN file is received by the TMDB, the LORDN Transaction Identifier of the previously sent LORDN file **MUST** be provided to the Registry. The TMDB **MUST** ignore the DN Lines present in the LORDN file if a LORDN file with the same <LORDN creation datetime> was previously sent.

The HTTP Location header field contains the URI where the LORDN Log file could be retrieved later, for example:

202 Accepted

Location: `https://<tmdb-domain-name>/LORDN/example/sunrise/000000000000000001/result`

- The interface provides an HTTP/400 if the request is incorrect or the syntax of the LORDN file is incorrect. The TMDB **MUST** return a human-readable message in the HTTP Entity-body regarding the incorrect syntax of the LORDN file.
- The interface provides an HTTP/401 status code if the credentials provided do not authorize the Registry Operator to upload a LORDN file.
- The TMDB **MUST** return an HTTP/404 status code when trying to upload a LORDN file using the `https://<tmdb-domain-name>/LORDN/<TLD>/sunrise/qlp` or `https://<tmdb-domain-name>/LORDN/<TLD>/claims/qlp` interface outside of a QLP Period plus 26 hours.
- The interface provides an HTTP/500 status code if the system is experiencing a general failure.

For example, to upload the Sunrise LORDN file for TLD "example", the URI would be:

`https://<tmdb-domain-name>/LORDN/example/sunrise`

The LORDN is contained in a CSV-formatted file that has the following structure:

- For Sunrise Period:
  - first line: `<version>,<LORDN creation datetime>,<Number of DN Lines>`

Where:

    - `<version>`: version of the file. This field **MUST** be 1.
    - `<LORDN creation datetime>`: date and time in UTC that the LORDN was created.
    - `<Number of DN Lines>`: number of DN Lines present in the LORDN file.
  - second line: a header line, as specified in [RFC4180]

With the header names as follows:

```
roid, domain-name, SMD-id, registrar-id, registration-datetime, application-datetime
```
  - One or more lines with: `<roid>,<DN registered>,<SMD-id>,<IANA Registrar id>,<datetime of registration>,<datetime of application creation>`

Where:

    - `<roid>`: DN Repository Object Identifier (DNROID) in the SRS.
    - `<DN registered>`: DN that was effectively allocated. For IDNs, the A-label form is used.
    - `<SMD-id>`: SMD ID used for registration.
    - `<IANA Registrar ID>`: IANA Registrar ID.

- <datetime of registration>: date and time in UTC that the domain was effectively allocated.
- **OPTIONAL** <datetime of application creation>: date and time in UTC that the application was created. The <datetime of application creation> **MUST** be provided in case of a DN effective allocation based on an asynchronous registration (e.g., when using auctions).

Example of a Sunrise LORDN file:

```
1,2012-08-16T00:00:00.0Z,3
roid, domain-name, SMD-id, registrar-id, registration-datetime, \
  application-datetime
SH8013-REP, example1.gtld, 1-2, 9999, 2012-08-15T13:20:00.0Z, \
  2012-07-15T00:50:00.0Z
EK77-REP, example2.gtld, 2-2, 9999, 2012-08-15T14:00:03.0Z
HB800-REP, example3.gtld, 3-2, 9999, 2012-08-15T15:40:00.0Z
```

Figure 12: Example Sunrise LORDN File

- For the Trademark Claims Period:
  - first line: <version>,<LORDN creation datetime>,<Number of DN Lines>
 

Where:

    - <version>: version of the file. This field **MUST** be 1.
    - <LORDN creation datetime>: date and time in UTC that the LORDN was created.
    - <Number of DN Lines>: number of DN Lines present in the LORDN file.
  - second line: a header line, as specified in [\[RFC4180\]](#)

With the header names as follows:

```
roid, domain-name, notice-id, registrar-id, registration-datetime, ack-datetime, application-datetime
```
  - One or more lines with: <roid>,<DN registered>,<TCNID>,<IANA Registrar id>,<datetime of registration>,<datetime of acceptance of the TCN>,<datetime of application creation>
 

Where:

    - <roid>: DNROID in the SRS.
    - <DN registered>: DN that was effectively allocated. For IDNs, the A-label form is used.
    - <TCNID>: Trademark Claims Notice Identifier, as specified in <tmNotice:id>.
    - <IANA Registrar ID>: IANA Registrar ID.
    - <datetime of registration>: date and time in UTC that the domain was effectively allocated.
    - <datetime of acceptance of the TCN>: date and time in UTC that the TCN was acknowledged.

- **OPTIONAL** <datetime of application creation>: date and time in UTC that the application was created. The <datetime of application creation> **MUST** be provided in case of a DN effective allocation based on an asynchronous registration (e.g., when using auctions).

For a DN matching a DNL of a PRM at the moment of registration, created without the TCNID, expiration datetime, and acceptance datetime because DNL was inserted (or reinserted) for the first time into a DNL List less than 24 hours ago, the string "recent-dnl-insertion" **MAY** be specified in <TCNID> and <datetime of acceptance of the TCN>.

Example of a Trademark Claims LORDN file:

```
1,2012-08-16T00:00:00.0Z,3
roid, domain-name, notice-id, registrar-id, registration-datetime, \
  ack-datetime, application-datetime
SH8013-REP, example1.gtld, a76716ed9223352036854775808, \
  9999, 2012-08-15T14:20:00.0Z, 2012-08-15T13:20:00.0Z
EK77-REP, example2.gtld, a7b786ed9223372036856775808, \
  9999, 2012-08-15T11:20:00.0Z, 2012-08-15T11:19:00.0Z
HB800-REP, example3.gtld, recent-dnl-insertion, \
  9999, 2012-08-15T13:20:00.0Z, recent-dnl-insertion
```

Figure 13: Example Trademark Claims LORDN File

### 6.3.1. LORDN Log File

After reception of the LORDN file, the TMDB verifies its content for syntactical and semantic correctness. The output of the LORDN file verification is retrieved using the yd interface ([Section 4.3.7](#)).

The URIs of the yd interface ([Section 4.3.7](#)) used to retrieve the LORDN Log file are:

- Sunrise LORDN Log file:  
https://<tmdb-domain-name>/LORDN/<TLD>/sunrise/<lordn-transaction-identifier>/result
- Trademark Claims LORDN Log file:  
https://<tmdb-domain-name>/LORDN/<TLD>/claims/<lordn-transaction-identifier>/result

A Registry Operator **MUST NOT** send more than one request per minute per TLD to download a LORDN Log file.

The yd interface ([Section 4.3.7](#)) returns the following HTTP status codes after an HTTP GET request method is received:

- The interface provides an HTTP/200 status code if the interface was able to provide the LORDN Log file. The LORDN Log file is contained in the HTTP Entity-body.
- The interface provides an HTTP/204 status code if the LORDN Transaction Identifier is correct but the server has not finalized processing the LORDN file.



- The interface provides an HTTP/400 status code if the request is incorrect.
- The interface provides an HTTP/401 status code if the credentials provided do not authorize the Registry Operator to download the LORDN Log file.
- The interface provides an HTTP/404 status code if the LORDN Transaction Identifier is incorrect.
- The interface provides an HTTP/500 status code if the system is experiencing a general failure.

For example, to obtain the LORDN Log file in case of a Sunrise LORDN file with LORDN Transaction Identifier 00000000000000000001 and TLD "example", the URI would be:

`https://<tmdb-domain-name>/LORDN/example/sunrise/00000000000000000001/result`

The LORDN Log file is contained in a CSV-formatted file that has the following structure:

- first line: <version>,<LORDN Log creation datetime>,<LORDN file creation datetime>,<LORDN Log Identifier>,<Status flag>,<Warning flag>,<Number of DN Lines>

Where:

- <version>: version of the file. This field **MUST** be 1.
- <LORDN Log creation datetime>: date and time in UTC that the LORDN Log was created.
- <LORDN file creation datetime>: date and time in UTC of creation for the LORDN file that this log file is referring to.
- <LORDN Log Identifier>: unique identifier of the LORDN Log provided by the TMDB. This identifier could be used by the Registry Operator to unequivocally identify the LORDN Log. The identifier will be a string of a maximum length of 60 characters from the base64 alphabet.
- <Status flag>: whether the LORDN file has been accepted for processing by the TMDB. Possible values are "accepted" or "rejected".
- <Warning flag>: whether the LORDN Log has any warning result codes. Possible values are "no-warnings" or "warnings-present".
- <Number of DN Lines>: number of DN effective allocations processed in the LORDN file.

A Registry Operator is not required to process a LORDN Log with <Status flag>="accepted" and <Warning flag>="no-warnings".

- second line: a header line, as specified in [\[RFC4180\]](#)

With the header names as follows:

`roid,result-code`

- One or more lines with: <roid>,<result code>

Where:

- <roid>: DNROID in the SRS.

- <result code>: result code, as described in [Section 6.3.1.1](#).

Example of a LORDN Log file:

```
1,2012-08-16T02:15:00.0Z,2012-08-16T00:00:00.0Z,\
 000000000000478Nzs+3VMkr8ckuUyn0LmyeqTmZQSbzDuf/R50n2n5QX4=,\
  accepted,no-warnings,1
roid,result-code
SH8013-REP,2000
```

Figure 14: Example LORDN Log File

### 6.3.1.1. LORDN Log Result Codes

The classes of result codes (rc) are listed below. The classes in square brackets are not used at this time but may come into use at some later stage. The first two digits of a result code denote the result code class, which defines the outcome at the TMDB:

- ok: Success. The DN Line is accepted by the TMDB.
- warn: A warning is issued. The DN Line is accepted by the TMDB.
- err: An error is issued. The LORDN file is rejected by the TMDB.

In cases where a DN line is processed and the error result code is 45xx or 46xx, the LORDN file **MUST** be rejected by the TMDB. If the LORDN file is rejected, DN Lines that are syntactically valid will be reported with a 2001 result code. A 2001 result code means that the DN Line is syntactically valid; however, the DN Line was not processed because the LORDN file was rejected. All DNs reported in a rejected LORDN file **MUST** be reported again by the Registry because none of the DN Lines present in the LORDN file have been processed by the TMDB.

LORDN Log Result Code Classes:

Code	Class	Outcome
20xx	Success	ok
35xx	[ DN Line syntax warning ]	warn
36xx	DN Line semantic warning	warn
45xx	DN Line syntax error	err
46xx	DN Line semantic error	err

Table 2: LORDN Log Result Code Classes

In [Table 3](#), the LORDN Log result codes used by the TMDB are described.

<b>rc</b>	<b>Short Description / Long Description</b>
2000	OK The DN Line is successfully processed.
2001	OK but not processed The DN Line is syntactically correct but was not processed because the LORDN file was rejected.
3601	TCN Acceptance Date after Registration Date The TCN Acceptance Date in the DN Line is newer than the registration date.
3602	Duplicate DN Line This DN Line is an exact duplicate of another DN Line in the same file; the DN Line is ignored.
3603	DNROID Notified Earlier The same DNROID has been notified earlier; the DN Line is ignored.
3604	TCN Checksum invalid Based on the DN effective allocation, the TCNID, and the expiration date of the linked TCN, the TCN Checksum is invalid.
3605	TCN Expired The TCN was already expired (based on the <tmNotice:notAfter> field of the TCN) at the datetime of acknowledgement.
3606	Wrong TCNID used The TCNID used for the registration does not match the related DN.
3609	Invalid SMD used The SMD used for registration was not valid at the moment of registration based on the <smd:notBefore> and <smd:notAfter> elements. In case of an asynchronous registration, this refers to the <datetime of application creation>.
3610	DN reported outside of the time window The DN was reported outside of the required 26-hour reporting window.
3611	DN does not match the labels in SMD

<b>rc</b>	<b>Short Description / Long Description</b>
	The DN does not match the labels included in the SMD.
3612	SMDID does not exist The Signed Mark Data Identifier (SMDID) has never existed in the central repository.
3613	SMD was revoked when used The SMD used for registration was revoked more than 24 hours ago of the <datetime of registration>. In case of an asynchronous registration, the <datetime of application creation> is used when validating the DN Line.
3614	TCNID does not exist The Trademark Claims Notice Identifier (TCNID) has never existed in the central repository.
3615	Recent-dnl-insertion outside of the time window The DN registration is reported as a recent-dnl-insertion, but the (re) insertion into the DNL occurred more than 24 hours ago.
3616	Registration Date of DN in Claims before the end of the Sunrise Period The registration date of the DN is before the end of the Sunrise Period, and the DN was reported in a Trademark Claims LORDN file.
3617	Registrar has not been approved by the TMDB The Registrar ID in the DN Line has not completed Trademark Claims integration testing with the TMDB.
3618	Registration Date of DN in QLP LORDN file out of the QLP Period The registration date of the DN in a QLP LORDN file is outside of the QLP Period.
3619	TCN was not valid The TCN was not valid (based on the <tmNotice:notBefore> field of the TCN) at the datetime of acknowledgement.
4501	Syntax Error in DN Line There is a syntax error in the DN Line.
4601	Invalid TLD used

rc	Short Description / Long Description
	The TLD in the DN Line does not match what is expected for this LORDN.
4602	Registrar ID Invalid The Registrar ID in the DN Line is not a valid ICANN-Accredited Registrar.
4603	Registration Date in the future The <datetime of registration> in the DN Line is in the future.
4606	TLD not in Sunrise or Trademark Claims Periods The <datetime of registration> was reported when the TLD was not in Sunrise or Trademark Claims Periods. In case of an asynchronous registration, the <datetime of application creation> is used when validating the DN Line.
4607	Application Date in the future The <datetime of application creation> in the DN Line is in the future.
4608	Application Date is later than Registration Date The <datetime of application creation> in the DN Line is later than the <datetime of registration>.
4609	TCNID wrong syntax The syntax of the TCNID is invalid.
4610	TCN Acceptance Date is in the future The <datetime of acceptance of the TCN> is in the future.
4611	Label has never existed in the TMDB The label in the registered DN has never existed in the TMDB.

Table 3: LORDN Log Result Codes

#### 6.4. Signed Mark Data (SMD) File

This section defines the format of the SMD File. After a successful registration of a mark, the TMV returns an SMD File to the TMH. The SMD File can then be used for registration of one or more DNs covered by the PRM during the Sunrise Period of a TLD.

Two encapsulation boundaries are defined for delimiting the encapsulated base64-encoded SMD: "-----BEGIN ENCODED SMD-----" and "-----END ENCODED SMD-----". Only data inside the encapsulation boundaries **MUST** be used by Registries and Registrars for validation purposes, i.e., any data outside these boundaries as well as the boundaries themselves **MUST** be ignored for validation purposes.

The structure of the SMD File is as follows. All the elements are **REQUIRED** and **MUST** appear in the specified order.

1. Marks: <marks>
2. smdID: <SMD-ID>
3. U-labels: <comma separated list of U-label or NR-LDH labels (see [RFC5890])>
4. notBefore: <begin validity>
5. notAfter: <end validity>
6. -----BEGIN ENCODED SMD-----
7. <encoded SMD (see [RFC7848])>
8. -----END ENCODED SMD-----

Example of an SMD file:

```
Marks: Example One
smdID: 1-2
U-labels: example-one, exampleone
notBefore: 2011-08-16 09:00
notAfter: 2012-08-16 09:00
-----BEGIN ENCODED SMD-----
PD94bWwgdmVyc2lvcj0iMS4wIiBlbmNvZGluZz0iVVRGLTgiPz4KPHNtZDpzaWdu
ZWRNYXJrIHhtbG5zOnNtZD0idXJuOm1ldGY6cGFyYW1zOnhtbDpuczpzaWduZWRN
... (base64 data elided for brevity) ...
dXJlPgo8L3NtZDpzaWduZWRNYXJrPgo=
-----END ENCODED SMD-----
```

Figure 15: Example SMD File

## 6.5. Trademark Claims Notice (TCN)

The TMDB **MUST** provide the TCN to Registrars in XML format, as specified below.

The enclosing element <tmNotice:notice> describes the Trademark Notice to a given label.

The child elements of the <tmNotice:notice> element include:

- A <tmNotice:id> element that contains the unique identifier of the Trademark Notice. This element contains the TCNID.

The TCNID is a string concatenation of a TCN Checksum and the TMDB Notice Identifier. The first 8 characters of the TCNID is a TCN Checksum. The rest is the TMDB Notice

Identifier, which is a zero-padded natural number in the range of 00000000000000000001 to 9223372036854775807.

Example of a TCNID:

```
370d0b7c9223372036854775807.
```

Where:

- TCN Checksum=370d0b7c
- TMDB Notice Identifier=9223372036854775807

The TCN Checksum is an 8-character-long base16-encoded output of computing the CRC32 of the string concatenation of: label + unix\_timestamp(<tmNotice:notAfter>) + TMDB Notice Identifier.

The TMDB **MUST** use the Unix time conversion of the <tmNotice:notAfter> in UTC to calculate the TCN Checksum. Unix time is defined as the number of seconds that have elapsed since 1970-01-01T00:00:00Z, not counting leap seconds. For example, the conversion of 2010-08-16T09:00:00.OZ to Unix time is:

```
unix_time(2010-08-16T09:00:00.OZ)=1281949200
```

The TMDB uses the <tmNotice:label> and <tmNotice:notAfter> elements from the TCN along with the TMDB Notice Identifier to compute the TCN Checksum.

A Registry **MUST** use the leftmost DNL of the DN being effectively allocated, the expiration datetime of the TCN (provided by the Registrar), and the TMDB Notice Identifier extracted from the TCNID (provided by the Registrar) to compute the TCN Checksum. For example, if the DN "xn--mgbachtv.xn--mgbh0fb" is being effectively allocated, the leftmost DNL would be "xn--mgbachtv".

An example computation of the TCN Checksum is:

```
CRC32(example-one12819492009223372036854775807)=370d0b7c
```

- A <tmNotice:notBefore> element that contains the start of the valid date and time of the TCN.
- A <tmNotice:notAfter> element that contains the expiration date and time of the TCN.
- A <tmNotice:label> element that contains the DNL covered by a PRM.
- One or more <tmNotice:claim> elements that contain the Trademark Claims. The <tmNotice:claim> element contains the following child elements:
  - A <tmNotice:markName> element that contains the mark text string.
  - One or more <tmNotice:holder> elements that contain the information of the holder of the mark. An "entitlement" attribute is used to identify the entitlement of the holder; possible values are: owner, assignee, or licensee. The child elements of <tmNotice:holder> include:
    - An **OPTIONAL** <tmNotice:name> element that contains the name of the holder. <tmNotice:name> **MUST** be specified if <tmNotice:org> is not specified.
    - An **OPTIONAL** <tmNotice:org> element that contains the name of the organization holder of the mark. <tmNotice:org> **MUST** be specified if <tmNotice:name> is not specified.

- A `<tmNotice:addr>` element that contains the address information of the holder of a mark. `<tmNotice:addr>` contains the following child elements:
  - One, two, or three **OPTIONAL** `<tmNotice:street>` elements that contain the organization's street address.
  - A `<tmNotice:city>` element that contains the organization's city.
  - An **OPTIONAL** `<tmNotice:sp>` element that contains the organization's state or province.
  - An **OPTIONAL** `<tmNotice:pc>` element that contains the organization's postal code.
  - A `<tmNotice:cc>` element that contains the organization's country code. This a two-character code from [\[ISO3166-2\]](#).
- An **OPTIONAL** `<tmNotice:voice>` element that contains the organization's voice telephone number.
- An **OPTIONAL** `<tmNotice:fax>` element that contains the organization's facsimile telephone number.
- An **OPTIONAL** `<tmNotice:email>` element that contains the email address of the holder.
- Zero or more **OPTIONAL** `<tmNotice:contact>` elements that contain the information of the representative of the mark registration. A "type" attribute is used to identify the type of contact; possible values are: owner, agent, or third party. The child elements of `<tmNotice:contact>` include:
  - A `<tmNotice:name>` element that contains the name of the responsible person.
  - An **OPTIONAL** `<tmNotice:org>` element that contains the name of the organization of the contact.
  - A `<tmNotice:addr>` element that contains the address information of the contact. `<tmNotice:addr>` contains the following child elements:
    - One, two, or three **OPTIONAL** `<tmNotice:street>` elements that contain the contact's street address.
    - A `<tmNotice:city>` element that contains the contact's city.
    - An **OPTIONAL** `<tmNotice:sp>` element that contains the contact's state or province.
    - An **OPTIONAL** `<tmNotice:pc>` element that contains the contact's postal code.
    - A `<tmNotice:cc>` element that contains the contact's country code. This a two-character code from [\[ISO3166-2\]](#).
  - A `<tmNotice:voice>` element that contains the contact's voice telephone number.
  - An **OPTIONAL** `<tmNotice:fax>` element that contains the contact's facsimile telephone number.
  - A `<tmNotice:email>` element that contains the contact's email address.
- A `<tmNotice:jurDesc>` element that contains the name (in English) of the jurisdiction where the mark is protected. A `jurCC` attribute contains the two-character code of the jurisdiction where the mark was registered. This is a two-character code from [\[WIPO.ST3\]](#).



- Zero or more **OPTIONAL** `<tmNotice:classDesc>` elements that contain the description (in English) of the Nice Classification, as defined in [[WIPO-NICE-CLASSES](#)]. A `classNum` attribute contains the class number.
- A `<tmNotice:goodsAndServices>` element that contains the full description of the goods and services mentioned in the mark registration document.
- An **OPTIONAL** `<tmNotice:notExactMatch>` element signals that the claim notice was added to the TCN based on rules (e.g., [[Claims50](#)]) other than exact match (defined in [[MatchingRules](#)]). `<tmNotice:notExactMatch>` contains one or more of the following:
  - An **OPTIONAL** `<tmNotice:udrp>` element that signals that the claim notice was added because of a previously abused name included in a Uniform Domain-Name Dispute-Resolution Policy (UDRP) case. `<tmNotice:udrp>` contains:
    - A `<tmNotice:caseNo>` element that contains the UDRP case number used to validate the previously abused name.
    - A `<tmNotice:udrpProvider>` element that contains the name of the UDRP provider.
  - An **OPTIONAL** `<tmNotice:court>` element that signals that the claim notice was added because of a previously abused name included in a court's resolution. `<tmNotice:court>` contains:
    - A `<tmNotice:refNum>` element that contains the reference number of the court's resolution used to validate the previously abused name.
    - A `<tmNotice:cc>` element that contains the two-character code from [[ISO3166-2](#)] of the jurisdiction of the court.
    - A `<tmNotice:courtName>` element that contains the name of the court.

Example of a `<tmNotice:notice>` object:

```
<?xml version="1.0" encoding="UTF-8"?>
<tmNotice:notice
  xmlns:tmNotice="urn:ietf:params:xml:ns:tmNotice-1.0">
  <tmNotice:id>370d0b7c9223372036854775807</tmNotice:id>
  <tmNotice:notBefore>2010-08-14T09:00:00.0Z</tmNotice:notBefore>
  <tmNotice:notAfter>2010-08-16T09:00:00.0Z</tmNotice:notAfter>
  <tmNotice:label>example-one</tmNotice:label>
  <tmNotice:claim>
    <tmNotice:markName>Example One</tmNotice:markName>
    <tmNotice:holder entitlement="owner">
      <tmNotice:org>Example Inc.</tmNotice:org>
      <tmNotice:addr>
        <tmNotice:street>123 Example Dr.</tmNotice:street>
        <tmNotice:street>Suite 100</tmNotice:street>
        <tmNotice:city>Reston</tmNotice:city>
        <tmNotice:sp>VA</tmNotice:sp>
        <tmNotice:pc>20190</tmNotice:pc>
        <tmNotice:cc>US</tmNotice:cc>
      </tmNotice:addr>
    </tmNotice:holder>
    <tmNotice:contact type="owner">
      <tmNotice:name>Joe Doe</tmNotice:name>
      <tmNotice:org>Example Inc.</tmNotice:org>
      <tmNotice:addr>
        <tmNotice:street>123 Example Dr.</tmNotice:street>
        <tmNotice:street>Suite 100</tmNotice:street>
        <tmNotice:city>Reston</tmNotice:city>
        <tmNotice:sp>VA</tmNotice:sp>
        <tmNotice:pc>20190</tmNotice:pc>
        <tmNotice:cc>US</tmNotice:cc>
      </tmNotice:addr>
      <tmNotice:voice x="4321">+1.7035555555</tmNotice:voice>
      <tmNotice:email>jdoe@example.com</tmNotice:email>
    </tmNotice:contact>
    <tmNotice:jurDesc jurCC="US">USA</tmNotice:jurDesc>
    <tmNotice:classDesc classNum="35">
      Advertising; business management; business administration.
    </tmNotice:classDesc>
    <tmNotice:classDesc classNum="36">
      Insurance; financial affairs; monetary affairs; real estate.
    </tmNotice:classDesc>
    <tmNotice:goodsAndServices>
      Bardus populorum circumdabit se cum captiosus populum.
      Smert populorum circumdabit se cum captiosus populum.
    </tmNotice:goodsAndServices>
  </tmNotice:claim>
  <tmNotice:claim>
    <tmNotice:markName>Example-One</tmNotice:markName>
    <tmNotice:holder entitlement="owner">
      <tmNotice:org>Example S.A. de C.V.</tmNotice:org>
      <tmNotice:addr>
        <tmNotice:street>Calle conocida #343</tmNotice:street>
        <tmNotice:city>Conocida</tmNotice:city>
        <tmNotice:sp>SP</tmNotice:sp>
        <tmNotice:pc>82140</tmNotice:pc>
        <tmNotice:cc>BR</tmNotice:cc>
      </tmNotice:addr>
```

```
</tmNotice:holder>
<tmNotice:jurDesc jurCC="BR">BRAZIL</tmNotice:jurDesc>
<tmNotice:goodsAndServices>
Bardus populorum circumdabit se cum captiosus populum.
Smert populorum circumdabit se cum captiosus populum.
</tmNotice:goodsAndServices>
</tmNotice:claim>
<tmNotice:claim>
<tmNotice:markName>One</tmNotice:markName>
<tmNotice:holder entitlement="owner">
<tmNotice:org>One Corporation</tmNotice:org>
<tmNotice:addr>
<tmNotice:street>Otra calle</tmNotice:street>
<tmNotice:city>Otra ciudad</tmNotice:city>
<tmNotice:sp>OT</tmNotice:sp>
<tmNotice:pc>383742</tmNotice:pc>
<tmNotice:cc>CR</tmNotice:cc>
</tmNotice:addr>
</tmNotice:holder>
<tmNotice:jurDesc jurCC="CR">COSTA RICA</tmNotice:jurDesc>
<tmNotice:goodsAndServices>
Bardus populorum circumdabit se cum captiosus populum.
Smert populorum circumdabit se cum captiosus populum.
</tmNotice:goodsAndServices>
<tmNotice:notExactMatch>
<tmNotice:court>
<tmNotice:refNum>234235</tmNotice:refNum>
<tmNotice:cc>CR</tmNotice:cc>
<tmNotice:courtName>Supreme Court of Spain</tmNotice:courtName>
</tmNotice:court>
</tmNotice:notExactMatch>
</tmNotice:claim>
<tmNotice:claim>
<tmNotice:markName>One Inc</tmNotice:markName>
<tmNotice:holder entitlement="owner">
<tmNotice:org>One SA de CV</tmNotice:org>
<tmNotice:addr>
<tmNotice:street>La calle</tmNotice:street>
<tmNotice:city>La ciudad</tmNotice:city>
<tmNotice:sp>CD</tmNotice:sp>
<tmNotice:pc>34323</tmNotice:pc>
<tmNotice:cc>AR</tmNotice:cc>
</tmNotice:addr>
</tmNotice:holder>
<tmNotice:jurDesc jurCC="AR">ARGENTINA</tmNotice:jurDesc>
<tmNotice:goodsAndServices>
Bardus populorum circumdabit se cum captiosus populum.
Smert populorum circumdabit se cum captiosus populum.
</tmNotice:goodsAndServices>
<tmNotice:notExactMatch>
<tmNotice:udrp>
<tmNotice:caseNo>D2003-0499</tmNotice:caseNo>
<tmNotice:udrpProvider>WIPO</tmNotice:udrpProvider>
</tmNotice:udrp>
</tmNotice:notExactMatch>
```

```
</tmNotice:claim>
</tmNotice:notice>
```

Figure 16: Example <tmNotice:notice> Object

For the formal syntax of the TCN, please refer to [Section 7.1](#).

## 6.6. Sunrise List (SURL)

This section defines the format of the list containing every DNL that matches a PRM eligible for Sunrise. The list is maintained by the TMDB and downloaded by Registries in regular intervals (see [Section 5.4.2.1](#)). The Registries use the Sunrise List during the QLP Period to check whether a requested DN matches a DNL of a PRM eligible for Sunrise.

The Sunrise List contains all the DNLs covered by a PRM eligible for Sunrise that are present in the TMDB at the datetime it is generated.

The Sunrise List is contained in a CSV-formatted file that has the following structure:

- first line: <version>,<Sunrise List creation datetime>
  - Where:
    - <version>: version of the file. This field **MUST** be 1.
    - <Sunrise List creation datetime>: date and time in UTC that the Sunrise List was created.
- second line: a header line, as specified in [[RFC4180](#)]
  - With the header names as follows:
    - DNL,insertion-datetime
- One or more lines with: <DNL>,<DNL insertion datetime>
  - Where:
    - <DNL>: a Domain Name Label covered by a PRM eligible for Sunrise.
    - <DNL insertion datetime>: datetime in UTC that the DNL was first inserted into the Sunrise List. The possible two values of time for inserting a DNL to the Sunrise List are 00:00:00 and 12:00:00 UTC.

Example of a Sunrise List:

```
1,2012-08-16T00:00:00.0Z
DNL,insertion-datetime
example,2010-07-14T00:00:00.0Z
another-example,2012-08-16T00:00:00.0Z
anotherexample,2011-08-16T12:00:00.0Z
```

Figure 17: Example Sunrise List

To provide authentication and integrity protection, the Sunrise List will be PGP signed by the TMDB (see [Section 5.1.1.4](#)). The PGP signature of the Sunrise List can be found in the similar URI but with extension .sig, as shown below.

The URLs of the dy interface ([Section 4.3.3](#)) are:

- <https://<tmdb-domain-name>/dnl/surl-latest.csv>
- <https://<tmdb-domain-name>/dnl/surl-latest.sig>

## 7. Formal Syntax

### 7.1. Trademark Claims Notice (TCN)

The schema presented here is for a Trademark Claims Notice.

The CODE BEGINS and CODE ENDS tags are not part of the schema; they are used to note the beginning and ending of the schema for URI registration purposes.

```
<CODE BEGINS>
<?xml version="1.0" encoding="UTF-8"?>
<schema targetNamespace="urn:ietf:params:xml:ns:tmNotice-1.0"
  xmlns:tmNotice="urn:ietf:params:xml:ns:tmNotice-1.0"
  xmlns:mark="urn:ietf:params:xml:ns:mark-1.0"
  xmlns="http://www.w3.org/2001/XMLSchema"
  elementFormDefault="qualified">

  <annotation>
    <documentation>
      Schema for representing a Trademark Claim Notice.
    </documentation>
  </annotation>
  <import namespace="urn:ietf:params:xml:ns:mark-1.0"/>
  <element name="notice" type="tmNotice:noticeType"/>
  <complexType name="holderType">
    <sequence>
      <element name="name" type="token" minOccurs="0"/>
      <element name="org" type="token" minOccurs="0"/>
      <element name="addr" type="tmNotice:addrType"/>
      <element name="voice" type="mark:e164Type" minOccurs="0"/>
      <element name="fax" type="mark:e164Type" minOccurs="0"/>
      <element name="email" type="mark:minTokenType" minOccurs="0"/>
    </sequence>
    <attribute name="entitlement" type="mark:entitlementType"/>
  </complexType>
  <complexType name="noticeType">
    <sequence>
      <element name="id" type="tmNotice:idType"/>
      <element name="notBefore" type="dateTime"/>
      <element name="notAfter" type="dateTime"/>
      <element name="label" type="mark:labelType"/>
      <element name="claim" type="tmNotice:claimType" minOccurs="0"
        maxOccurs="unbounded"/>
    </sequence>
  </complexType>
</schema>
```

```
</complexType>
<complexType name="claimType">
  <sequence>
    <element name="markName" type="token"/>
    <element name="holder" type="tmNotice:holderType"
      maxOccurs="unbounded"/>
    <element name="contact" type="tmNotice:contactType"
      minOccurs="0" maxOccurs="unbounded"/>
    <element name="jurDesc" type="tmNotice:jurDescType"/>
    <element name="classDesc" type="tmNotice:classDescType"
      minOccurs="0" maxOccurs="unbounded"/>
    <element name="goodsAndServices" type="token"/>
    <element name="notExactMatch" type="tmNotice:noExactMatchType"
      minOccurs="0"/>
  </sequence>
</complexType>
<complexType name="jurDescType">
  <simpleContent>
    <extension base="token">
      <attribute name="jurCC" type="mark:ccType" use="required"/>
    </extension>
  </simpleContent>
</complexType>
<complexType name="classDescType">
  <simpleContent>
    <extension base="token">
      <attribute name="classNum" type="integer" use="required"/>
    </extension>
  </simpleContent>
</complexType>
<complexType name="noExactMatchType">
  <choice maxOccurs="unbounded">
    <element name="udrp" type="tmNotice:udrpType"/>
    <element name="court" type="tmNotice:courtType"/>
  </choice>
</complexType>
<complexType name="udrpType">
  <sequence>
    <element name="caseNo" type="token"/>
    <element name="udrpProvider" type="token"/>
  </sequence>
</complexType>
<complexType name="courtType">
  <sequence>
    <element name="refNum" type="token"/>
    <element name="cc" type="mark:ccType"/>
    <element name="region" type="token" minOccurs="0"
      maxOccurs="unbounded"/>
    <element name="courtName" type="token"/>
  </sequence>
</complexType>
<complexType name="addrType">
  <sequence>
    <element name="street" type="token" minOccurs="1"
      maxOccurs="3"/>
    <element name="city" type="token"/>
    <element name="sp" type="token" minOccurs="0"/>
    <element name="pc" type="mark:pcType" minOccurs="0"/>
  </sequence>
</complexType>
```

```
<element name="cc" type="mark:ccType" />
</sequence>
</complexType>
<complexType name="contactType">
  <sequence>
    <element name="name" type="token" />
    <element name="org" type="token" minOccurs="0" />
    <element name="addr" type="tmNotice:addrType" />
    <element name="voice" type="mark:e164Type" />
    <element name="fax" type="mark:e164Type" minOccurs="0" />
    <element name="email" type="mark:minTokenType" />
  </sequence>
  <attribute name="type" type="mark:contactTypeType" />
</complexType>
<simpleType name="idType">
  <restriction base="token">
    <pattern value="[a-fA-F0-9]{8}\d{1,19}" />
  </restriction>
</simpleType>
</schema>

<CODE ENDS>
```

## 8. IANA Considerations

The code point assigned in support of this document is taken from the wrong point in the registration tree. Unfortunately, the code point has already been deployed in the field without following the proper registration review process. The designated experts for the registry have considered the issues that correcting this action would cause for deployed implementations and have consented to the continued use of the code point.

This document uses URNs to describe XML namespaces and XML schemas conforming to a registry mechanism described in [RFC3688]. IANA has registered two URI assignments as follows.

Trademark Claims Notice namespace:

URI: urn:ietf:params:xml:ns:tmNotice-1.0

Registrant Contact: IETF <iesg@ietf.org> and ICANN <globalsupport@icann.org>

XML: None. Namespace URIs do not represent an XML specification.

Note: Note that this assignment is made from the wrong point in the tree in order to be consistent with deployed implementations.

Trademark Claims Notice XML schema:

URI: urn:ietf:params:xml:schema:tmNotice-1.0

Registrant Contact: IETF <iesg@ietf.org> and ICANN <globalsupport@icann.org>

XML: See [Section 7.1](#) of RFC 9361.

Note: Note that this assignment is made from the wrong point in the tree in order to be consistent with deployed implementations.

## 9. Security Considerations

This specification uses HTTP Basic Authentication to provide a simple application-layer authentication service. HTTPS is used in all interfaces in order to protect against most common attacks. In addition, the client identifier is tied to a set of IP addresses that are allowed to connect to the interfaces described in this document, providing an extra security measure.

The TMDB **MUST** provide credentials to the appropriate Registries and Registrars.

The TMDB **MUST** require the use of strong passwords by Registries and Registrars.

The TMDB, Registries, and Registrars **MUST** use the best practices described in [RFC9325] or its successors.

## 10. Privacy Considerations

This specification defines the interfaces to support the [RPM-Requirements]. Legal documents govern the interactions between the different parties, and such legal documents must ensure that privacy-sensitive and/or personal data receives the required protection.

## 11. References

### 11.1. Normative References

**[Claims50]** ICANN, "Implementation Notes: Trademark Claims Protection for Previously Abused Names", July 2013, <<https://newgtlds.icann.org/en/about/trademark-clearinghouse/previiously-abused-16jul13-en.pdf>>.

**[MatchingRules]** ICANN, "Explanatory Memorandum: Implementing the Matching Rules", July 2016, <<https://newgtlds.icann.org/en/about/trademark-clearinghouse/matching-rules-14jul16-en.pdf>>.

**[QLP-Addendum]** ICANN, "Trademark Clearinghouse Rights Protection Mechanism Requirements: Qualified Launch Program Addendum", April 2014, <<https://newgtlds.icann.org/en/about/trademark-clearinghouse/rpm-requirements-qlp-addendum-10apr14-en.pdf>>.

**[RFC2119]** Bradner, S., "Key words for use in RFCs to Indicate Requirement Levels", BCP 14, RFC 2119, DOI 10.17487/RFC2119, March 1997, <<https://www.rfc-editor.org/info/rfc2119>>.

**[RFC3688]** Mealling, M., "The IETF XML Registry", BCP 81, RFC 3688, DOI 10.17487/RFC3688, January 2004, <<https://www.rfc-editor.org/info/rfc3688>>.

**[RFC7848]** Lozano, G., "Mark and Signed Mark Objects Mapping", RFC 7848, DOI 10.17487/RFC7848, June 2016, <<https://www.rfc-editor.org/info/rfc7848>>.



- [RFC8174] Leiba, B., "Ambiguity of Uppercase vs Lowercase in RFC 2119 Key Words", BCP 14, RFC 8174, DOI 10.17487/RFC8174, May 2017, <<https://www.rfc-editor.org/info/rfc8174>>.
- [RFC9325] Sheffer, Y., Saint-Andre, P., and T. Fossati, "Recommendations for Secure Use of Transport Layer Security (TLS) and Datagram Transport Layer Security (DTLS)", BCP 195, RFC 9325, DOI 10.17487/RFC9325, November 2022, <<https://www.rfc-editor.org/info/rfc9325>>.
- [RPM-Requirements] ICANN, "Trademark Clearinghouse Rights Protection Mechanism Requirements", September 2013, <<https://newgtlds.icann.org/en/about/trademark-clearinghouse/rpm-requirements-30sep13-en.pdf>>.
- [W3C.REC-xml-20081126] Bray, T., Paoli, J., Sperberg-McQueen, C. M., Maler, E., and F. Yergeau, "Extensible Markup Language (XML) 1.0 (Fifth Edition)", W3C Recommendation REC-xml-20081126, November 2008, <<https://www.w3.org/TR/2008/REC-xml-20081126/>>.
- [W3C.REC-xmlschema-1-20041028] Thompson, H., Beech, D., Maloney, M., and N. Mendelsohn, "XML Schema Part 1: Structures Second Edition", W3C Recommendation REC-xmlschema-1-20041028, October 2004, <<https://www.w3.org/TR/2004/REC-xmlschema-1-20041028/>>.
- [W3C.REC-xmlschema-2-20041028] Biron, P. and A. Malhotra, "XML Schema Part 2: Datatypes Second Edition", W3C Recommendation REC-xmlschema-2-20041028, October 2004, <<https://www.w3.org/TR/2004/REC-xmlschema-2-20041028/>>.

## 11.2. Informative References

- [ICANN-GTLD-AGB-20120604] ICANN, "gTLD Applicant Guidebook Version 2012-06-04", June 2012, <<http://newgtlds.icann.org/en/applicants/agb/guidebook-full-04jun12-en.pdf>>.
- [ISO3166-2] ISO, "International Standard for country codes and codes for their subdivisions", <[http://www.iso.org/iso/home/standards/country\\_codes.htm](http://www.iso.org/iso/home/standards/country_codes.htm)>.
- [RFC3339] Klyne, G. and C. Newman, "Date and Time on the Internet: Timestamps", RFC 3339, DOI 10.17487/RFC3339, July 2002, <<https://www.rfc-editor.org/info/rfc3339>>.
- [RFC4180] Shafranovich, Y., "Common Format and MIME Type for Comma-Separated Values (CSV) Files", RFC 4180, DOI 10.17487/RFC4180, October 2005, <<https://www.rfc-editor.org/info/rfc4180>>.
- [RFC4648] Josefsson, S., "The Base16, Base32, and Base64 Data Encodings", RFC 4648, DOI 10.17487/RFC4648, October 2006, <<https://www.rfc-editor.org/info/rfc4648>>.
- [RFC4880] Callas, J., Donnerhacke, L., Finney, H., Shaw, D., and R. Thayer, "OpenPGP Message Format", RFC 4880, DOI 10.17487/RFC4880, November 2007, <<https://www.rfc-editor.org/info/rfc4880>>.

- [RFC5280]** Cooper, D., Santesson, S., Farrell, S., Boeyen, S., Housley, R., and W. Polk, "Internet X.509 Public Key Infrastructure Certificate and Certificate Revocation List (CRL) Profile", RFC 5280, DOI 10.17487/RFC5280, May 2008, <<https://www.rfc-editor.org/info/rfc5280>>.
- [RFC5890]** Klensin, J., "Internationalized Domain Names for Applications (IDNA): Definitions and Document Framework", RFC 5890, DOI 10.17487/RFC5890, August 2010, <<https://www.rfc-editor.org/info/rfc5890>>.
- [RFC7617]** Reschke, J., "The 'Basic' HTTP Authentication Scheme", RFC 7617, DOI 10.17487/RFC7617, September 2015, <<https://www.rfc-editor.org/info/rfc7617>>.
- [RFC8499]** Hoffman, P., Sullivan, A., and K. Fujiwara, "DNS Terminology", BCP 219, RFC 8499, DOI 10.17487/RFC8499, January 2019, <<https://www.rfc-editor.org/info/rfc8499>>.
- [RFC9110]** Fielding, R., Ed., Nottingham, M., Ed., and J. Reschke, Ed., "HTTP Semantics", STD 97, RFC 9110, DOI 10.17487/RFC9110, June 2022, <<https://www.rfc-editor.org/info/rfc9110>>.
- [WIPO-NICE-CLASSES]** WIPO, "Nice Classification", <<http://www.wipo.int/classifications/nice/en>>.
- [WIPO.ST3]** WIPO, "Recommended standard on two-letter codes for the representation of states, other entities and intergovernmental organizations", November 2022, <<https://www.wipo.int/export/sites/www/standards/en/pdf/03-03-01.pdf>>.

## Acknowledgements

This specification is a collaborative effort from several participants in the ICANN community. Bernie Hoeneisen participated as a coauthor for the first draft version of this document, providing invaluable support. This specification is based on a model spearheaded by Chris Wright, Jeff Neuman, Jeff Eckhaus, and Will Shorter. The author would also like to thank the thoughtful feedback provided by many in the tmch-tech mailing list but particularly the extensive help provided by James Gould, James Mitchell, and Francisco Arias. This document includes feedback received from Paul Hoffman.

## Author's Address

**Gustavo Lozano**  
ICANN  
12025 Waterfront Drive  
Suite 300  
Los Angeles, 90292  
United States of America  
Phone: +1.310.301.5800  
Email: [gustavo.lozano@icann.org](mailto:gustavo.lozano@icann.org)